

HAYMAKER II-B/T **ULTIMATE A/C** SYSTEM

INSTALLATION INSTRUCTIONS

©2016 RestomodAir / 04.16

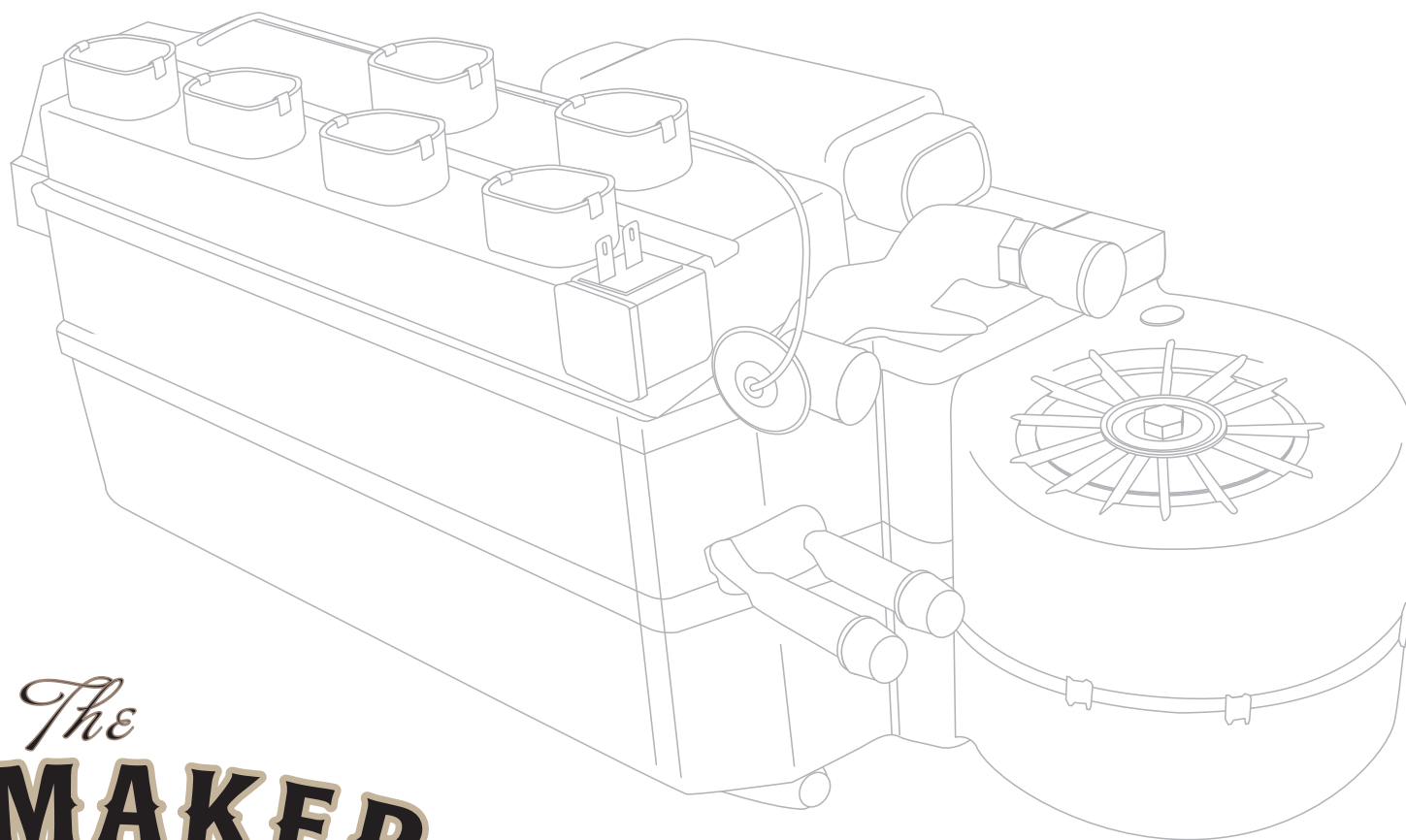

The
HAYMAKER
II
S Y S T E M



RESTOMOD AIR

Ultimate Style. Killer Performance.

HAYMAKER II-B/T ULTIMATE A/C SYSTEM

Congratulations, you snagged a Haymaker... the ultimate in after-market A/C. You've joined an exclusive group of owners that demand only the best of the best for their classic rides. You're going to love this thing, no matter what the weather is outside... you're going to be comfortable inside (and the bragging rights ain't too shabby either).

We know you're getting a Haymaker for a custom build... and you're going to install it your way... so these instructions are more of a overview.

You're a seasoned professional, but If you have any questions during the installation, please don't hesitate to call our kick-ass tech guys... hey, they might just want to shoot the shit and talk cars and girls.

From everyone here at Restomod Air, from the techies, polishers to the artists thanks again.

THIS IS OUR NUMBER, USE IT
866-784-4278

HAYMAKER II-B/T **ULTIMATE A/C** SYSTEM

Check List, Pre-Installation:

- ✓ Before beginning the installation check the shipping box for the correct components. YOUR BOXED UNIT INCLUDES A LIST OF MAJOR COMPONENTS AND A LIST OF BAGGED PARTS. We have a 5 stage check process to make sure you have everything you'll need.
- ✓ If your vehicle has been or is being modified, some procedures will need to be adjusted to fit your particular application.
- ✓ A basic cleaning of the engine compartment and interior before beginning will make things go more smoothly.
- ✓ Check condition of engine mounts. Excessive engine movement can damage hoses to A/C and/or heater.
- ✓ Drain the radiator. Retain the coolant and reuse, or dispose of properly.
- ✓ SAFETY FIRST: Wear eye protection while drilling/cutting, deburr sharp edges, and never get in a hurry or force a part.

Procedures, During Installation:

- ✓ Fittings: Use one or two drops of mineral oil (supplied with your kit) on ALL rubber o-rings, threads and rear of bump for o-ring where female nut rides. Do not use thread tape or sealants.
- ✓ Measure twice (or more), cut once
- ✓ Should you have any technical questions, or feel you have defective components (or missing items), call us immediately, we will be glad to assist you. Our toll-free number is listed on every page, we're here to help!

YOU CAN NOW BEGIN THE INSTALLATION...

A Basic Overview of Automotive A/C....

- 1 **Evaporator with Blower Fan** In order to remove the heat from the air in the vehicle, the A/C evaporator allows the refrigerant to absorb the heat from the air passing over it. The blower fan moves cool air out into the car interior.
- 2 **Compressor** The compressor pumps and circulates the refrigerant through the system.
- 3 **Condenser** The condenser is a heat exchanger mounted at the front of the vehicle. Heat drawn out of the interior of the car is expelled here.
- 4 **Receiver/Drier** The drier not only dries refrigerant, it also filters the refrigerant and stores it under certain operating conditions.
- 5 **High Pressure Switch** A pressure switch is used to shut down the system if high or low pressure is detected, basically it acts as a safety switch.

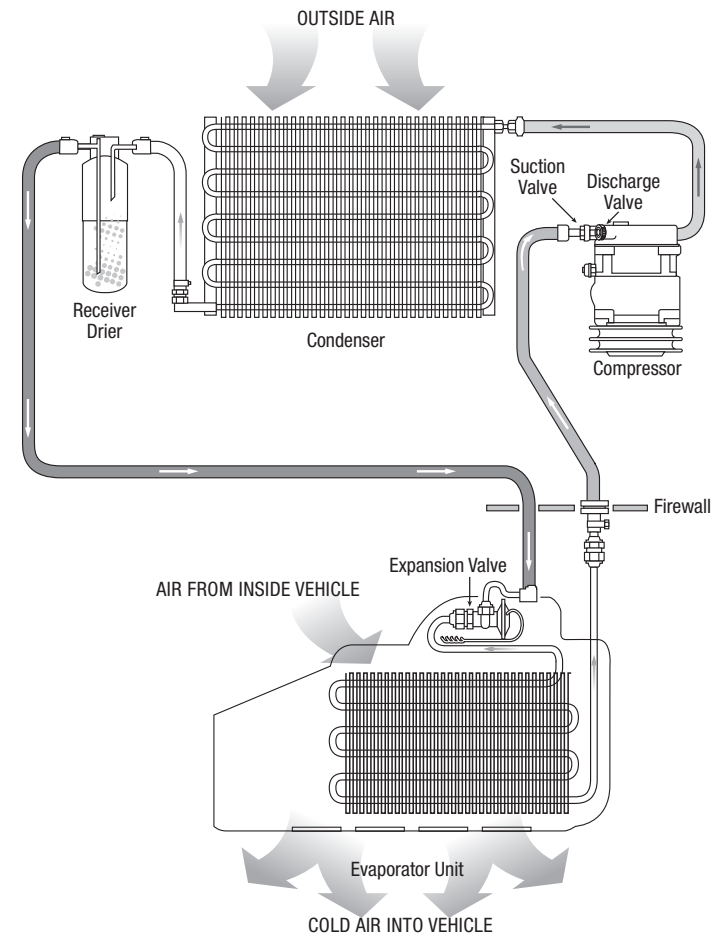
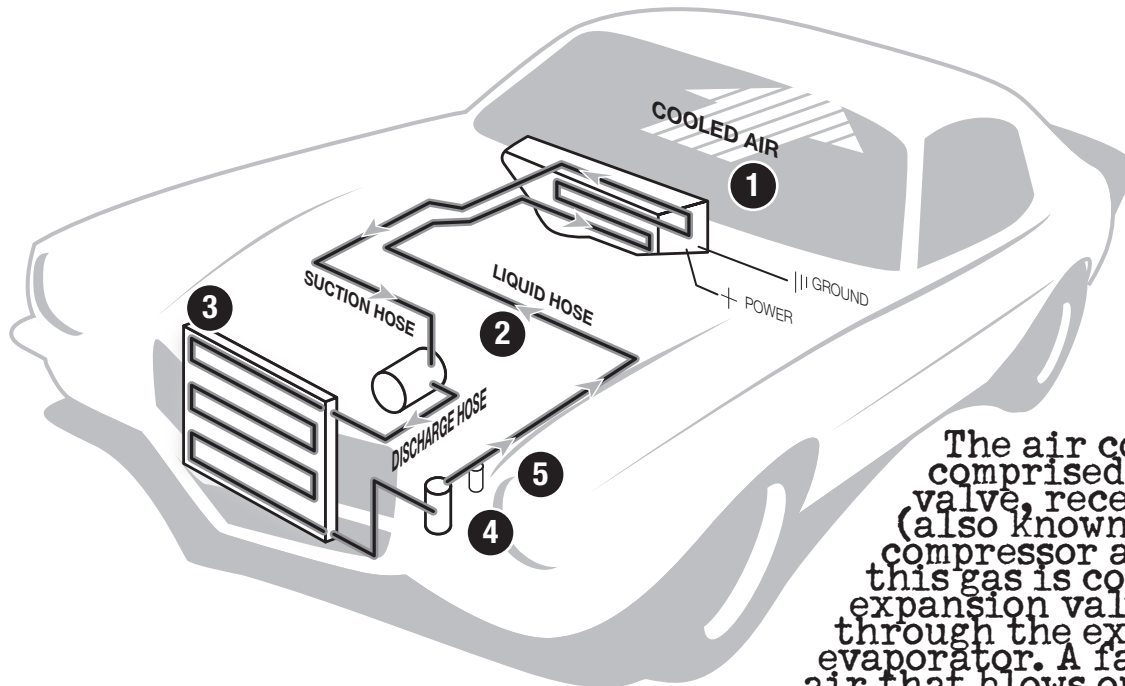

The air conditioning system in your car is comprised of a compressor, condenser, expansion valve, receiver/drier, and evaporator. Refrigerant (also known as Freon) is compressed in the compressor and turns into a gas. In the condenser, this gas is cooled to a liquid state and travels to the expansion valve. As the liquid refrigerant goes through the expansion valve it rapidly cools in the evaporator. A fan blows over the evaporator and cools the air that blows out your vents. The receiver-drier separates gas and liquid.

DOWNLOAD ATMOSPHERE APP

ATMOSPHERE

Before you get started you need to download the Restomod air App Atmosphere.



For all Apple devices go the App Store and search Restomod Air. The title of the app will be Restomod Atmosphere. Press get to install App.



For all Android devices go the Google Play Store and search Restomod Air. The title of the app will be Restomod Atmosphere. Press install App.



HARDWARE BOX

HAYMAKER II-B/T ULTIMATE A/C SYSTEM

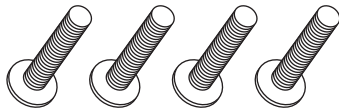

Four Weldable Studs

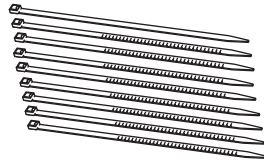

Eight Zip Ties

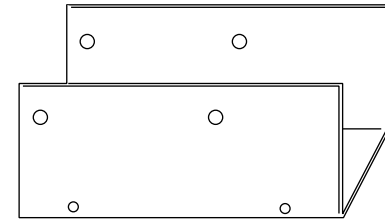

Back Mounting Bracket

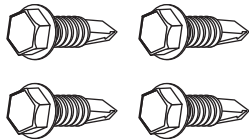

SIX #10 - 16 x 3/4" Tek Screws

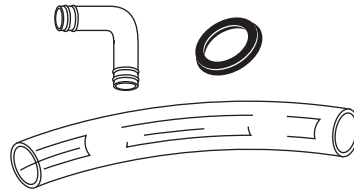

Clear Plastic Drain Tube w/ 90 degree elbow and grommet



Four # 1/4 - 20 x 1" Bolts, Washer and Lock Nuts

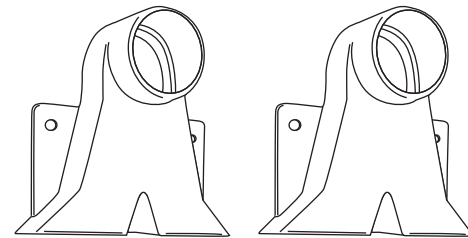

Two Remote Heat Dumps

KNOW YOUR SYSTEM

HAYMAKER II-B/T SYSTEM ULTIMATE A/C

Within the following pages we will outline the installation steps of your new Haymaker II system. Since this is a custom installation and varies based on your particular vehicle, many of our procedures can be viewed as “suggestions”... and your personal preferences will play a major role in the actual installation.

Take a moment to familiarize yourself with the heart of your new system, the evaporator case.

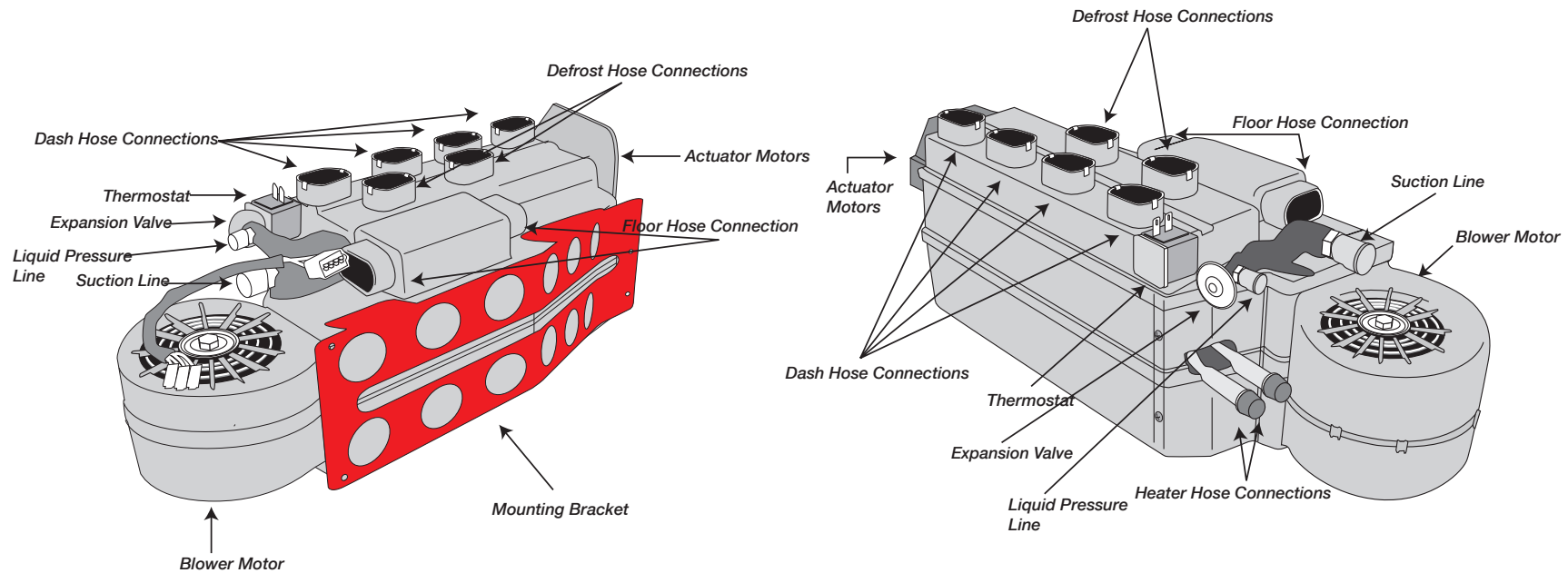

HAYMAKER II-B/T **ULTIMATE A/C** SYSTEM

General Procedures and Vehicle Preparation

Our HAYMAKER SYSTEM is designed to be flexible in it's final mounting location, but generally the dash area behind the glove box area is the most common and practical. We've included several options for how you can mount the evaporator.

- It's a good idea to visualize the final outcome of all components before cutting into your vehicle. If you're really unsure about a component fitting, you can always make a paper or cardboard mock up first. Measure twice, cut once.
- The mounting location of the evaporator is usually determined by two factors, space and your desired way to route the heater and A/C hoses.
- Duct hose routing and vent locations should be given careful consideration before final mounting is selected. Position the vents to give you optimal air flow. Route hoses so they will not interfere with the operation of controls or other mechanisms.
- Wrap all exposed metal on suction tube or fittings to ensure no condensation will form inside of vehicle and drip on floorboard or blower motor.
- Retain all parts you remove until after the installation is completely finished.

Vehicle Preparation:

- Before beginning your installation, DISCONNECT THE BATTERY. Next, remove glove box (and console, if equipped) for more space to work within.
- Remove all OEM heater unit and A/C components. You may be able to reuse the factory style defrost vents.
- Before installation, double check the firewall and transmission tunnel area for any holes or cracks that may allow hot engine air into the interior of the car. Be sure to seal all of these before completing installation.

FITTING BOX

HAYMAKER II-B/T **ULTIMATE A/C** SYSTEM



Refrigerant Tape

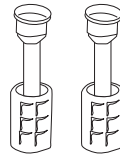

TWO #6 FIO Straight

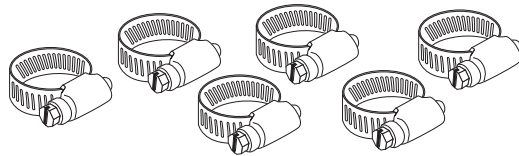

Six Worm Gear Clamps

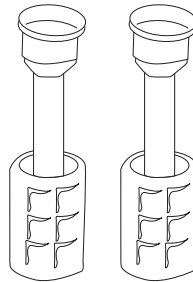

TWO #10 FIO Straight

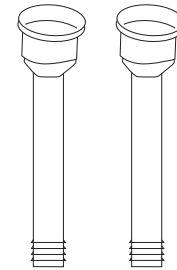

TWO #10 Straight Heater Fittings

INSTALLATION/GENERAL TIPS

HAYMAKER II-B/T ULTIMATE A/C SYSTEM

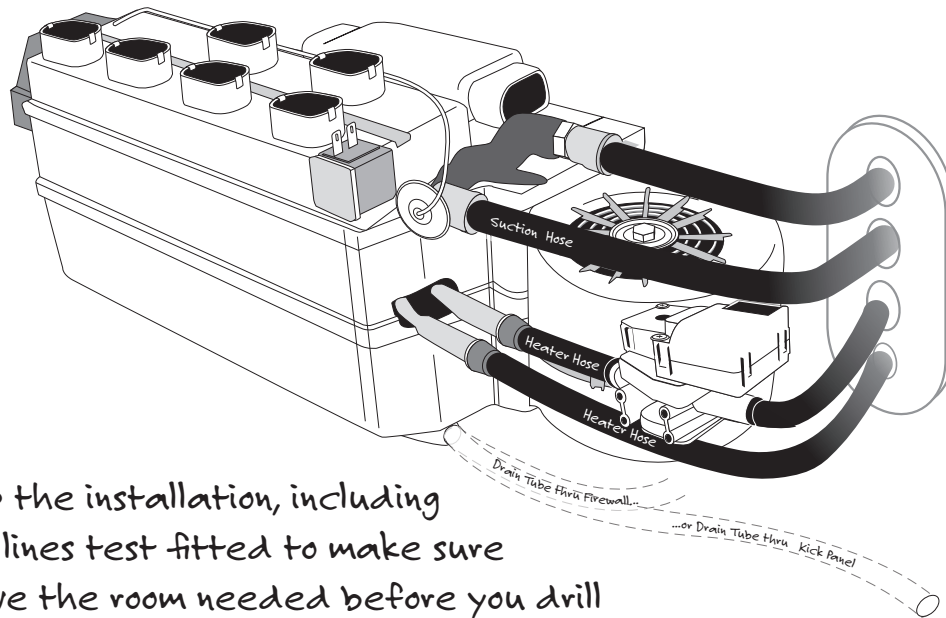

- Mock up the installation, including with the lines test fitted to make sure you'll have the room needed before you drill holes or weld the studs to your firewall.

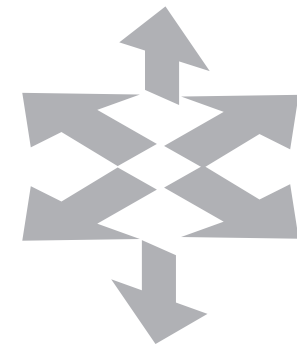

Use whatever method you like to securely mount the evaporator (we show you two options on the next pages).

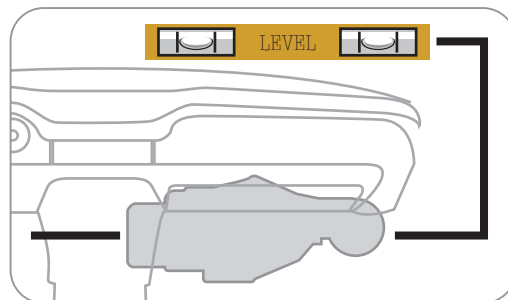

Be sure to align the evaporator unit level with the bottom of instrument panel (assuming the vehicle is sitting level). This will allow for proper drainage of condensation.

BULKHEAD INSTALLATION

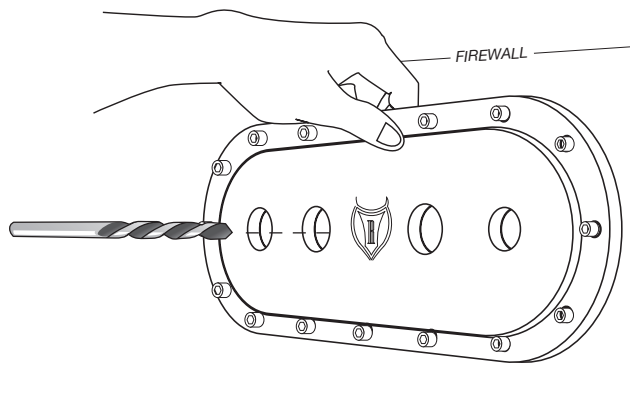

Find a nice flat surface to install your bulk head and make sure that the area you selected is clear of any obstructions or components that can be damaged.

Use the bulkhead to mock up your holes for the hoses.

TIP: When installing the bulkhead make sure to follow the instructions for your particular bulkhead.

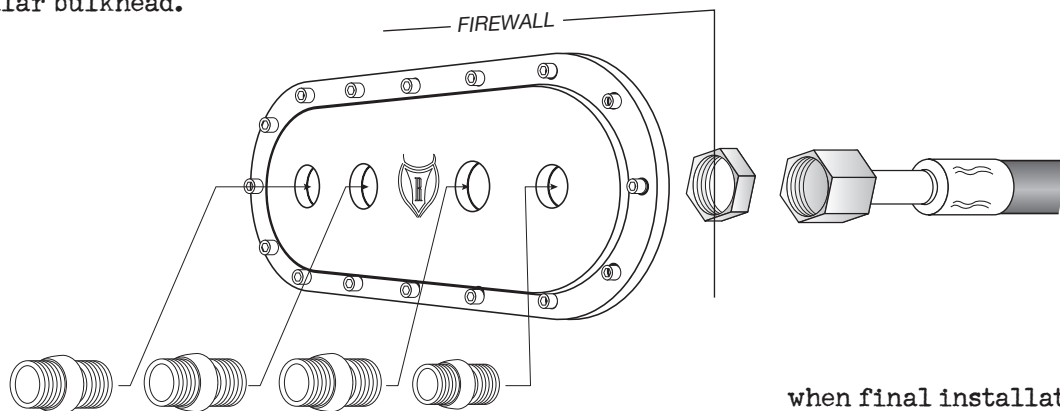

After drilling any holes, carefully deburr them to eliminate any potential snags.

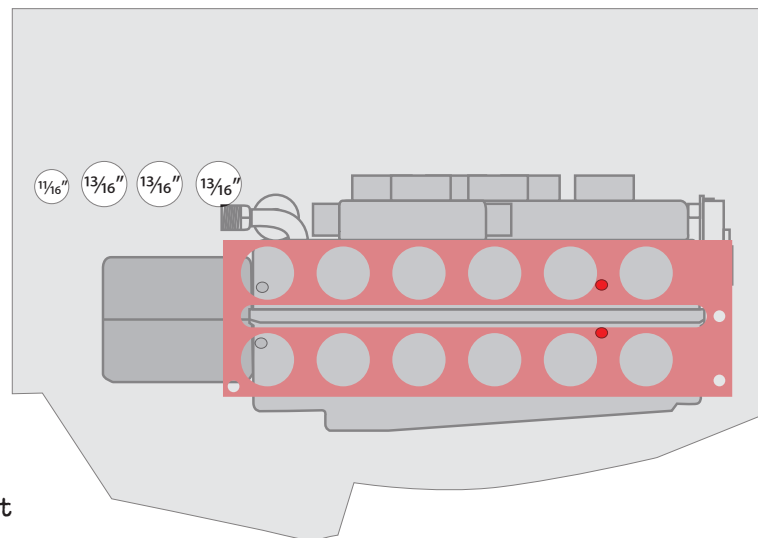

Standard sizes for the fitting are 13/16" for the heater and suction hoses. The liquid hose needs a 11/16" hole.



Reminder... Use two wrenches to tighten o-ring fittings and a few drops of mineral oil on the rings also.

when final installation of hoses is done be sure to use the proper O-rings and a few drops of mineral oil in each connection.

NO BULKHEAD INSTALLATION

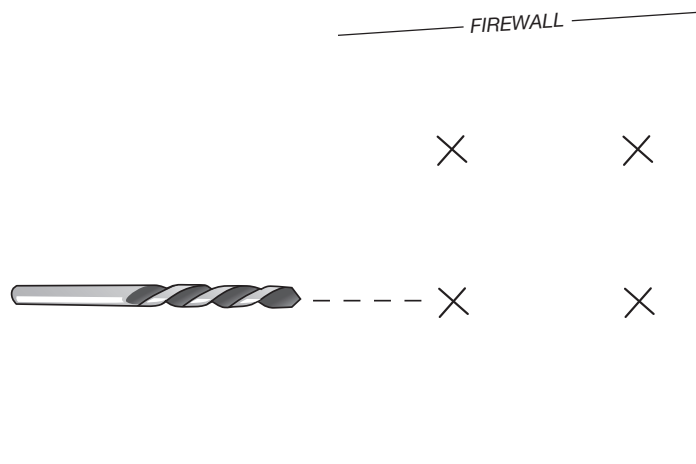

When drilling make sure to check for obstructions on either side of the firewall.

We recommend using grommets if a bulkhead plate is not utilized.

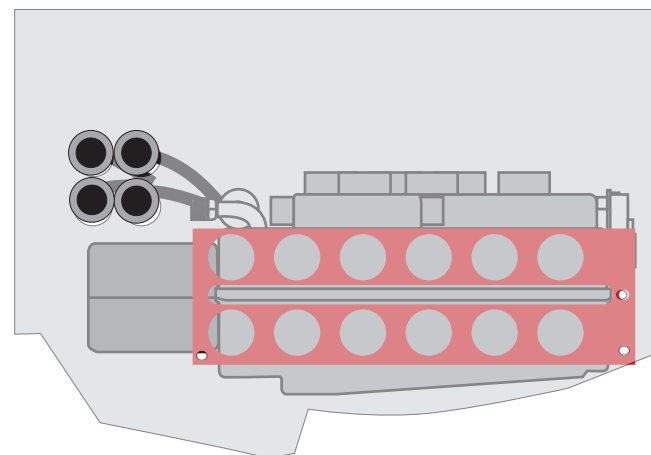
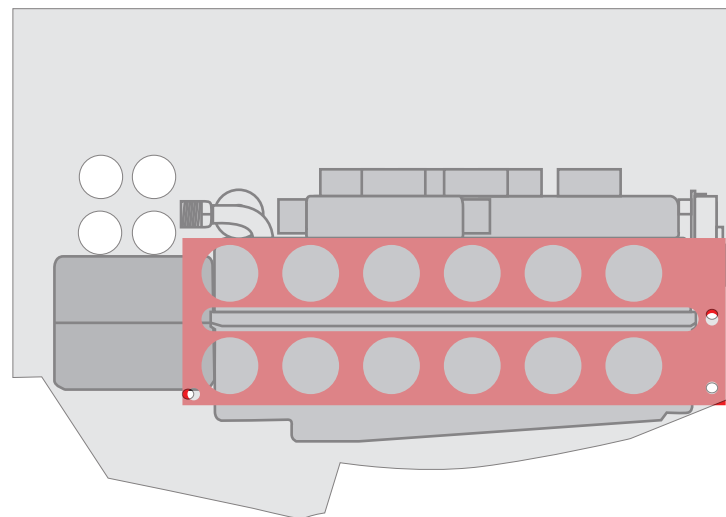
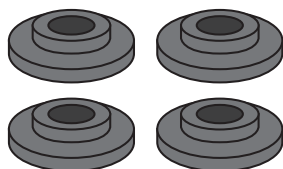

Route the hoses thru the fire wall into the engine bay.

FLAT FIREWALL INSTALLATION

INSTALLATION
STEP 1

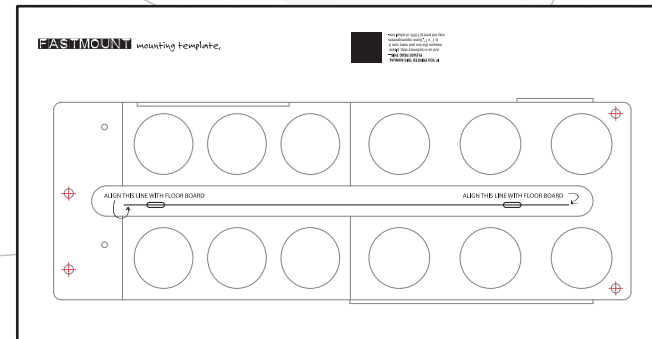
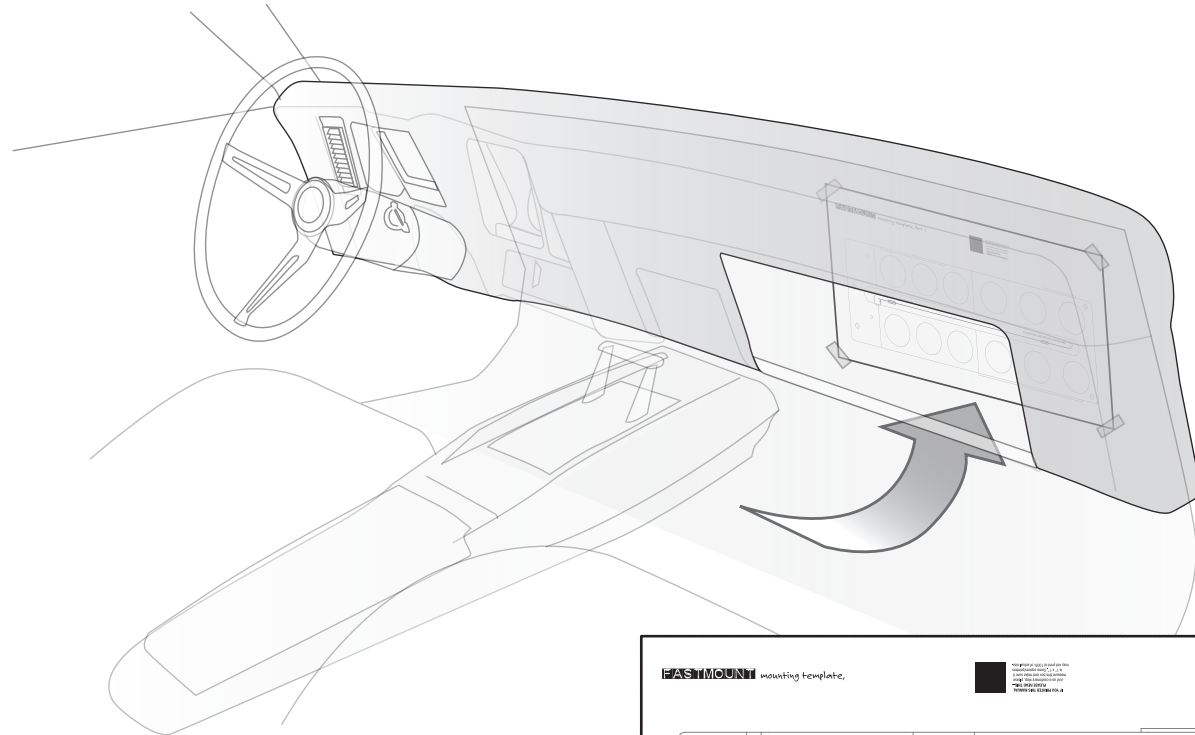

Step 1
Tape template to inside firewall.
Mark 4 locations (be sure to follow
guide line for proper leveling)

FLAT FIREWALL INSTALLATION

INSTALLATION
STEP 2

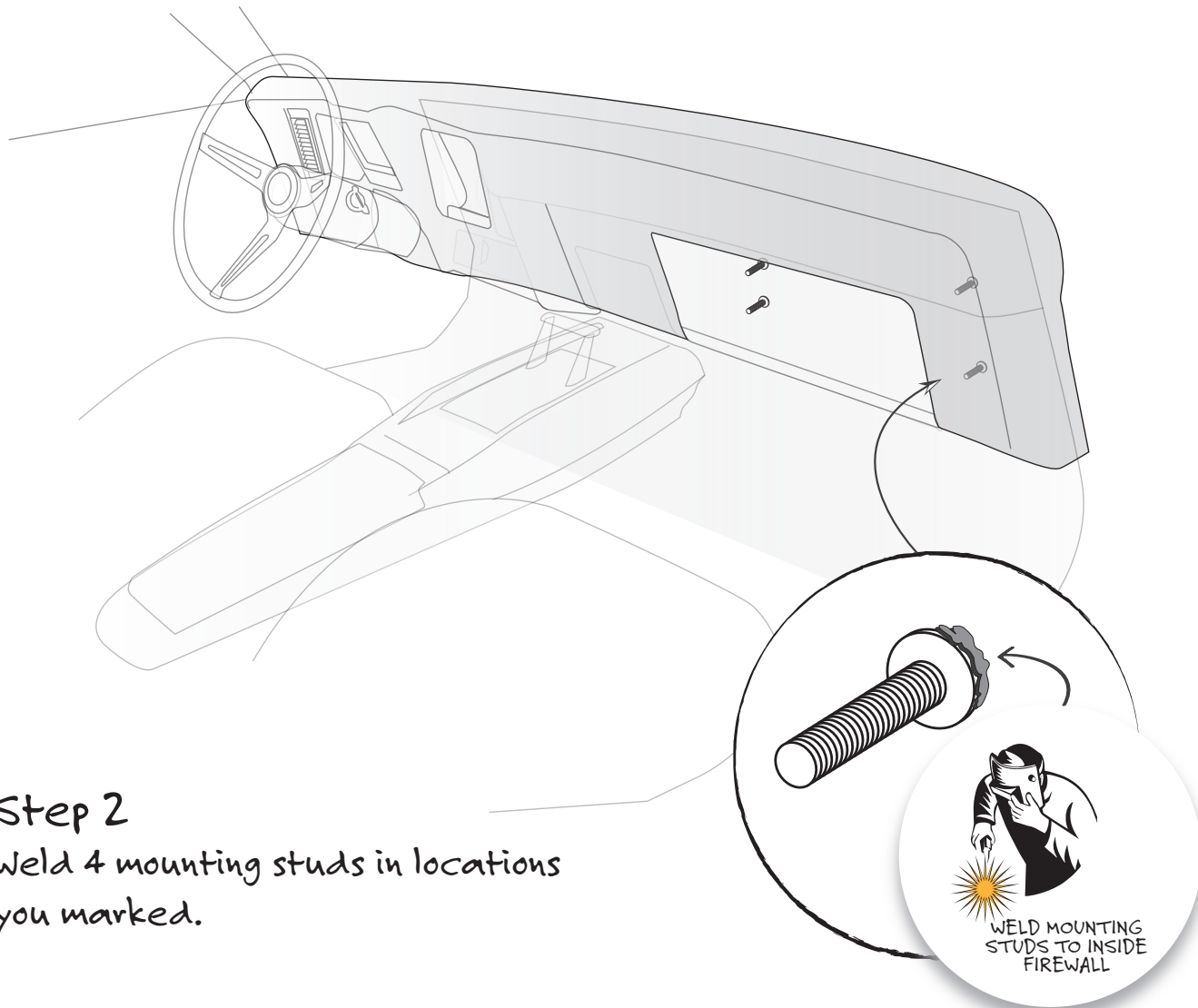

Step 2
Weld 4 mounting studs in locations
you marked.

FLAT FIREWALL INSTALLATION

INSTALLATION
STEP 2

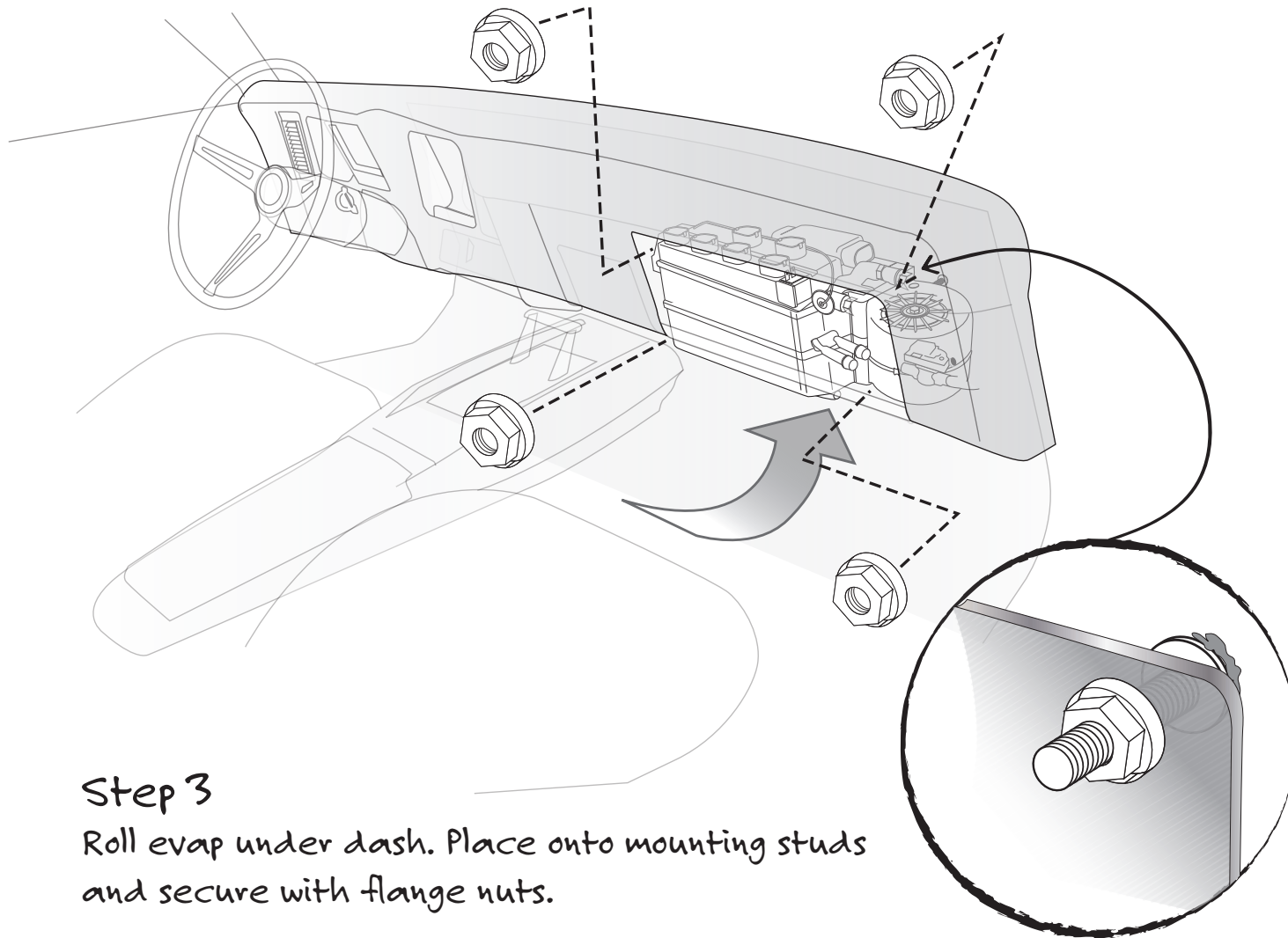

Step 3

Roll evap under dash. Place onto mounting studs and secure with flange nuts.

BOLT-IN INSTALLATION

INSTALLATION
STEP 1

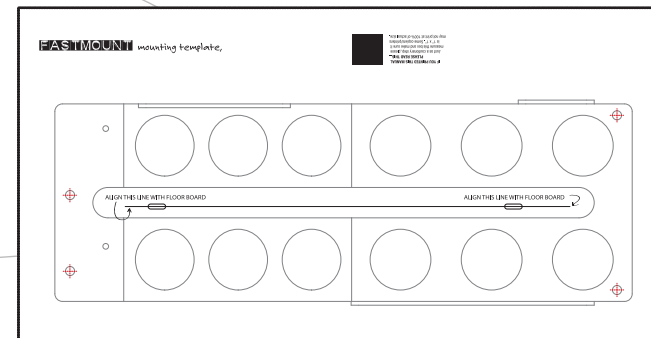
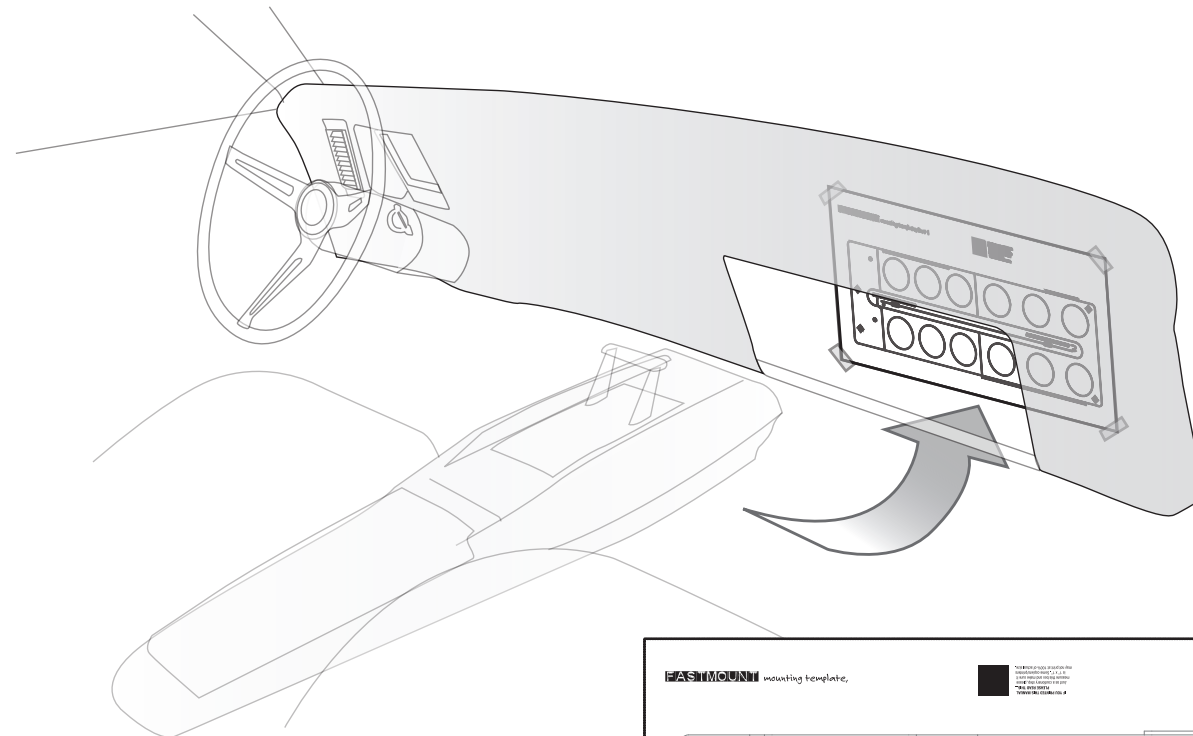

Step 1
Tape template to inside firewall.
Mark 4 locations (be sure to follow
guide line for proper leveling)

BOLT-IN INSTALLATION

INSTALLATION
STEP 2

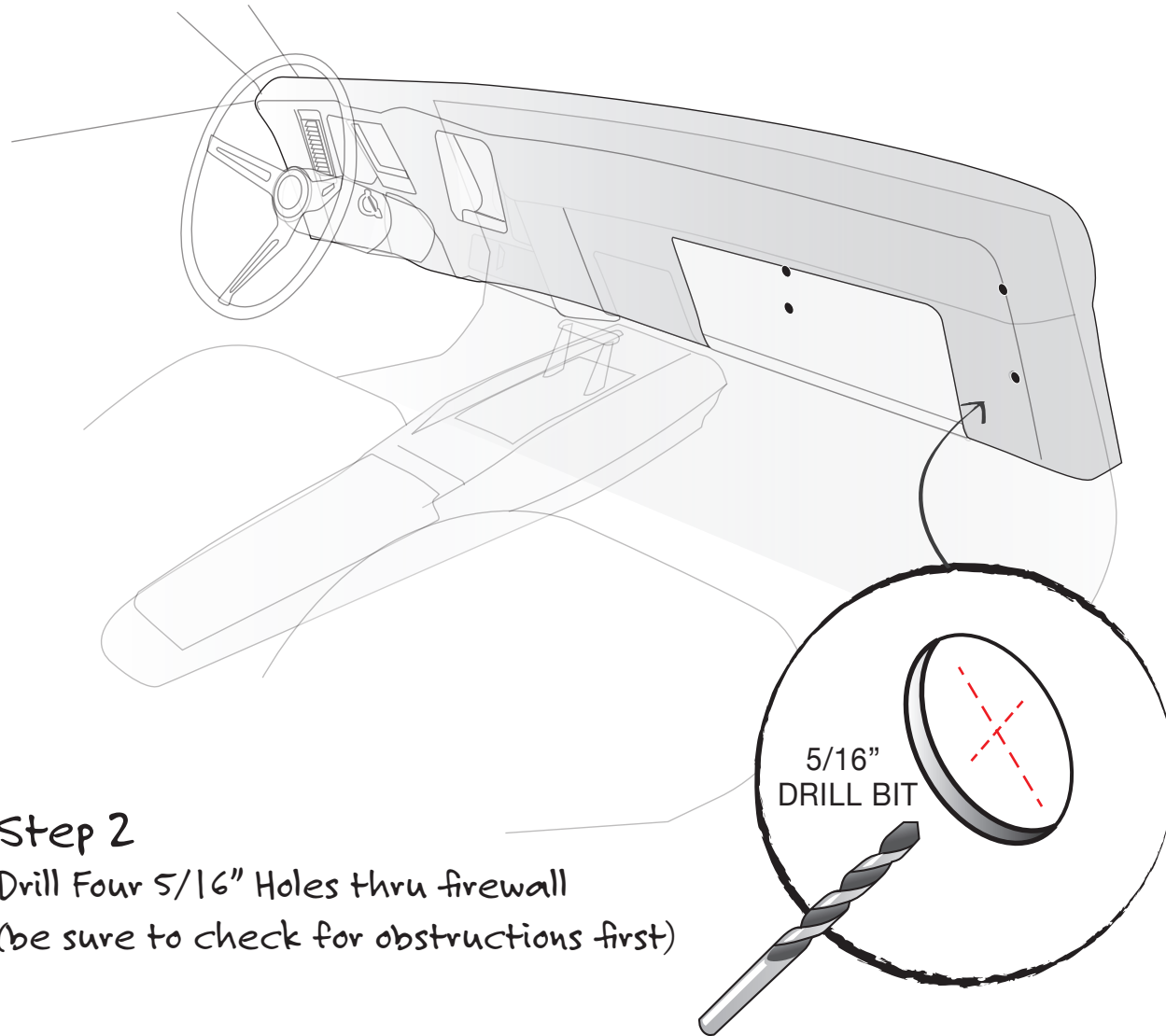

Step 2
Drill Four 5/16" Holes thru firewall
(be sure to check for obstructions first)

BOLT-IN INSTALLATION

INSTALLATION
STEP 3

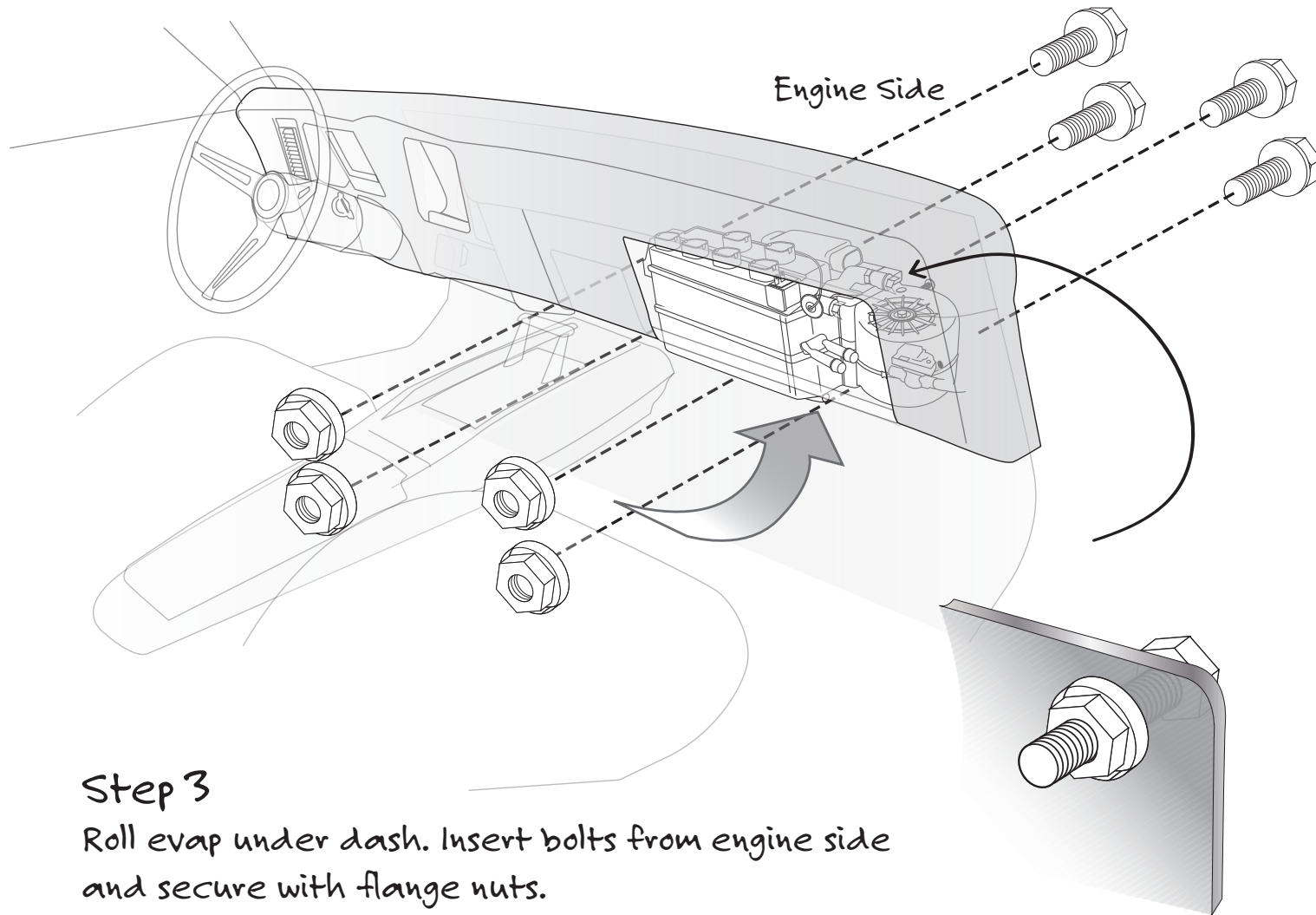

Step 3

Roll evap under dash. Insert bolts from engine side and secure with flange nuts.

HAYMAKER II-B/T ^{ULTIMATE A/C} SYSTEM

YOU BETTER FREAKIN READ THIS

Next, route all A/C and heater hoses from evaporator unit to your firewall. Make sure you have the correct orientation on the electronic water valve...

IMPORTANT NOTICE... WATER VALVE MUST BE INSTALLED PER

THESE INSTRUCTIONS: The lower connection on the tubes coming thru the block off assembly is going to be routed to the water outlet on the intake manifold. Attach your hose with cable clamps on both ends and route where it will not interfere with linkage or come in contact with exhaust manifolds or headers.

The water valve can be connected to either heater connection on the evaporator unit. Make certain the water valve is connected to the hose that connects to the **WATER PUMP**, If you only remember one thing during this installation make certain that the water valve goes to the water pump. We are stopping the flow of coolant leaving the heater core!

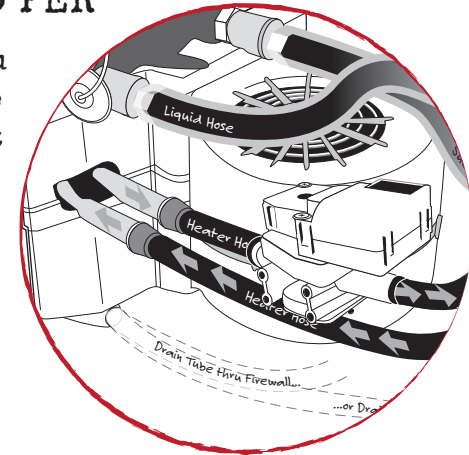

For a cleaner installation, we recommend mounting the electronic water valve in the interior area next to the evaporator

Locate a mounting place for the ECU in a location near the evaporator unit. Don't permanently mount it just yet, you can do that after you calibrate it.

HAYMAKER II-B/T ULTIMATE A/C SYSTEM

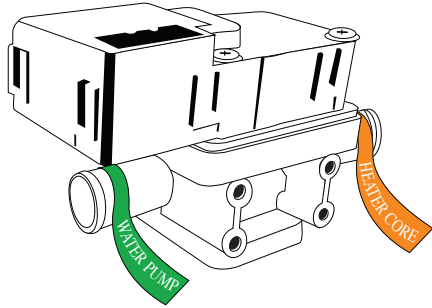

Electronic Water Control Valve

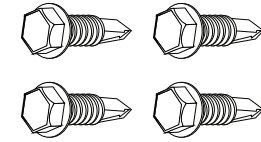

FOUR #10 - 16 x 3/4" Tek Screws

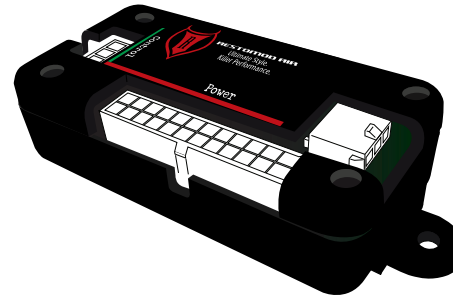

RESTOMOD ECU
BLUETOOTH

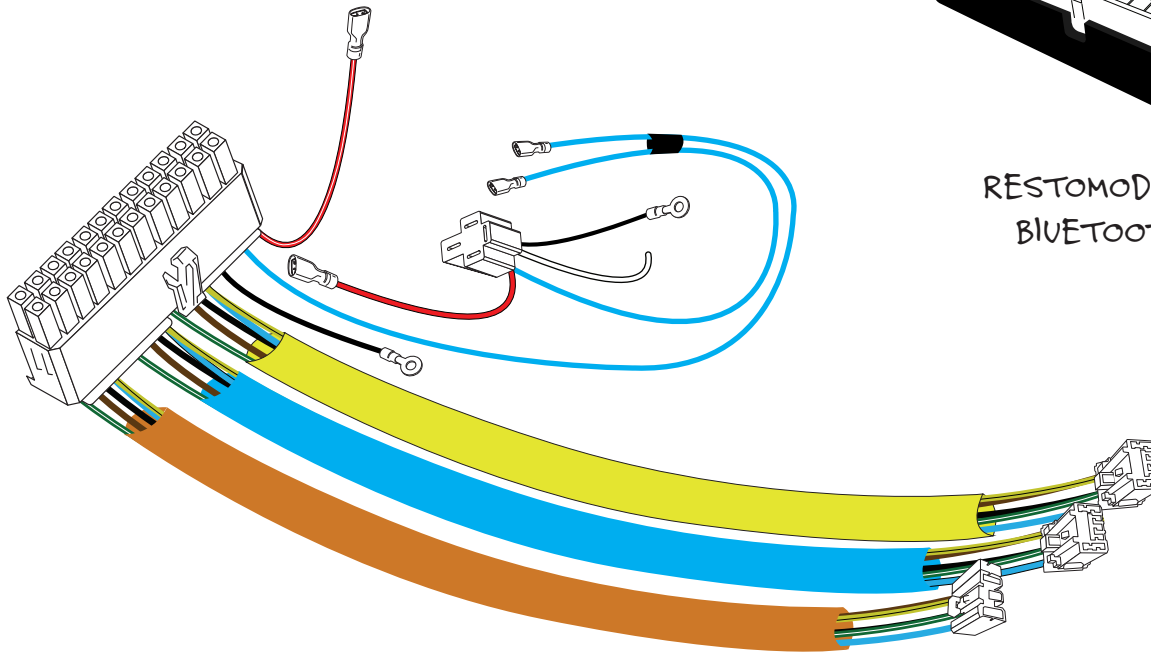

Main Power Harness

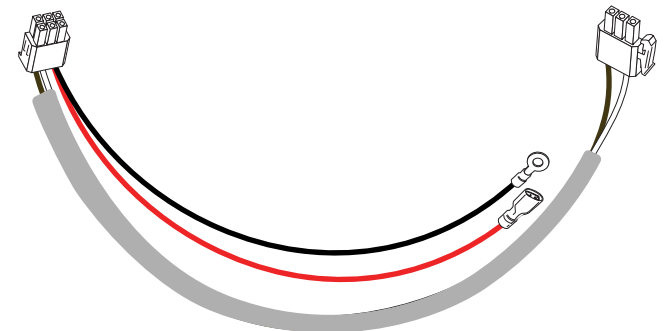

Bluetooth Harness

CONNECT MAIN POWER TO ECU

STEP 1

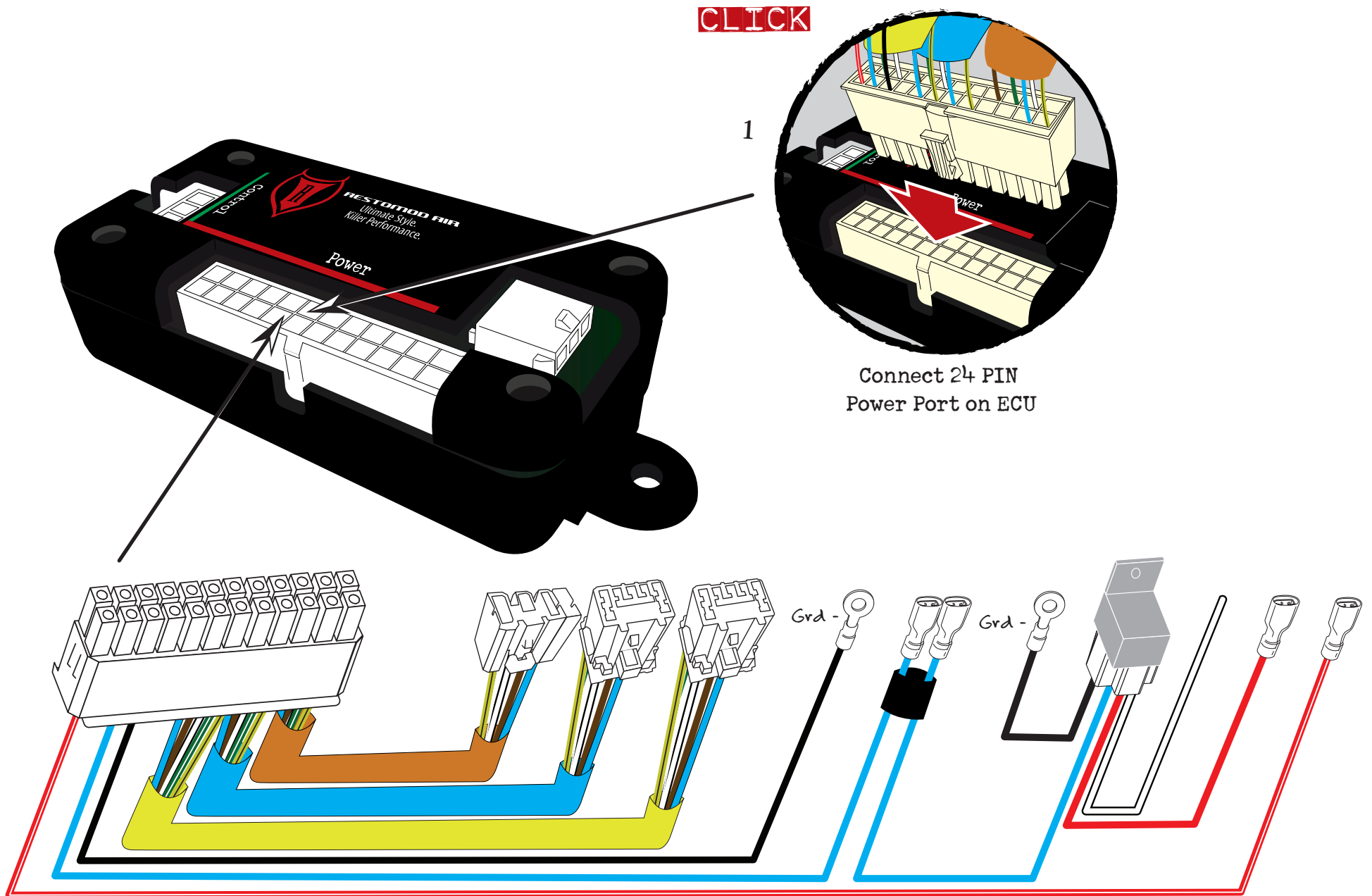

CONNECT TO EVAPORATOR

STEPS 2-4

CLICK

2

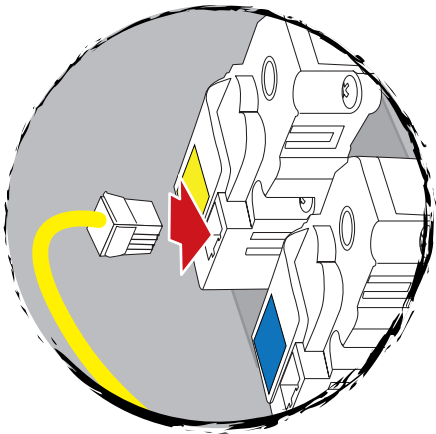

Connect **YELLOW** Harness into Face/ Floor Servo Motor

CLICK

3

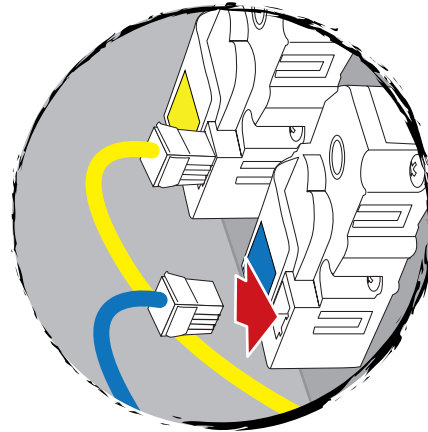

Connect **BLUE** Harness into Defrost Servo Motor

CLICK

4

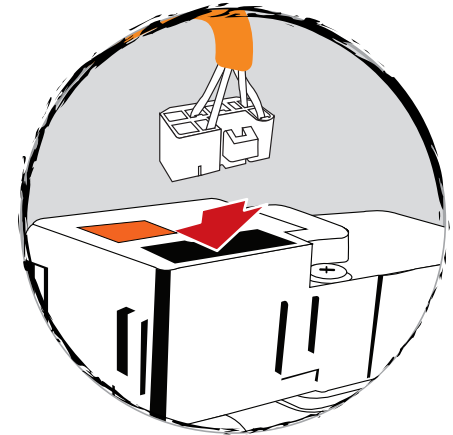

Connect **ORANGE** Harness into water valve

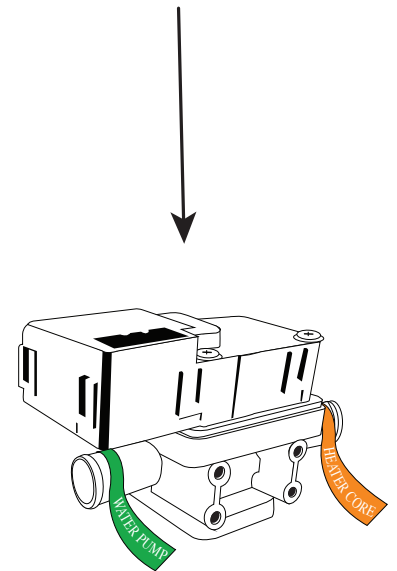
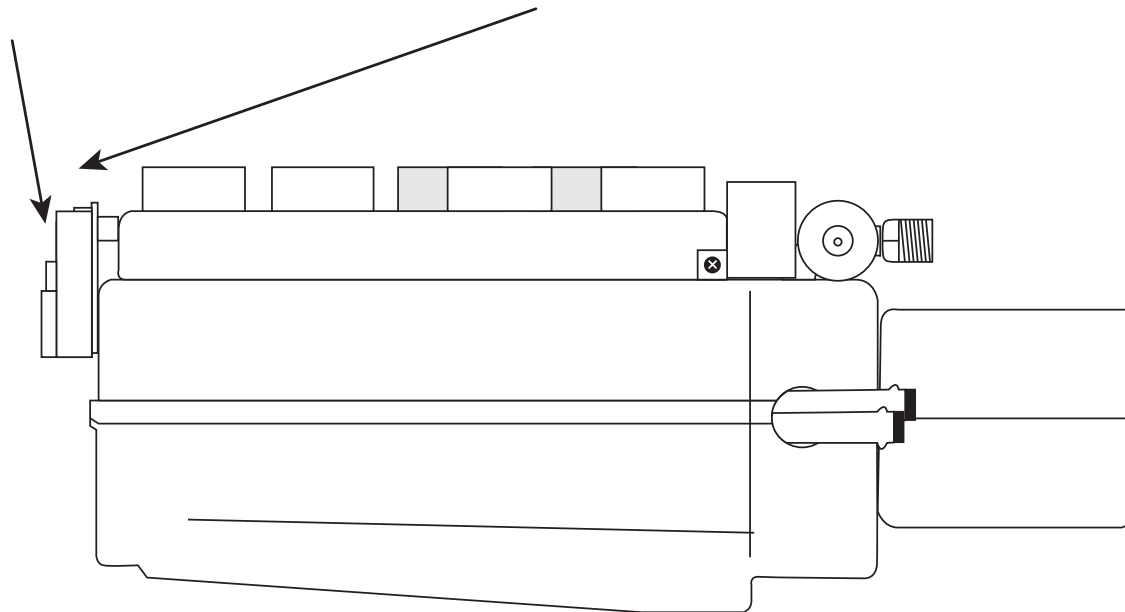

MAIN POWER HARNESS

STEPS 5-7

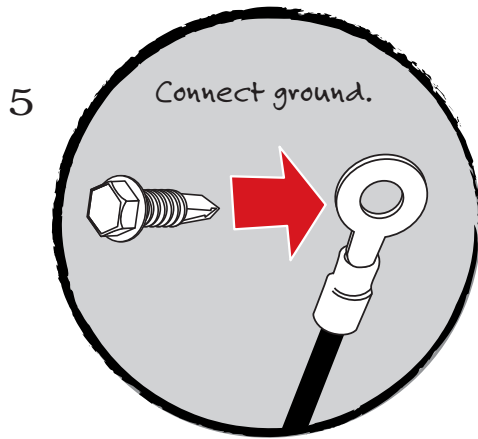

Ground Black.

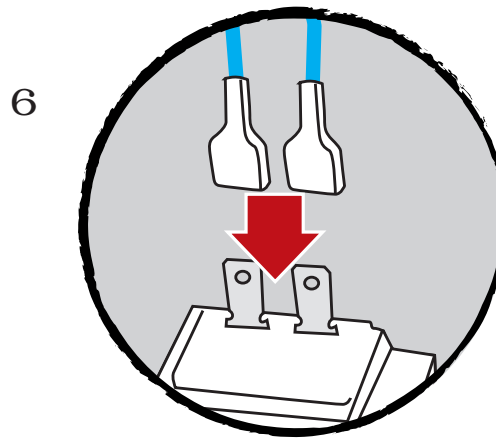

Connect both BLUE leads into
Thermostat
(either lead into either terminal)

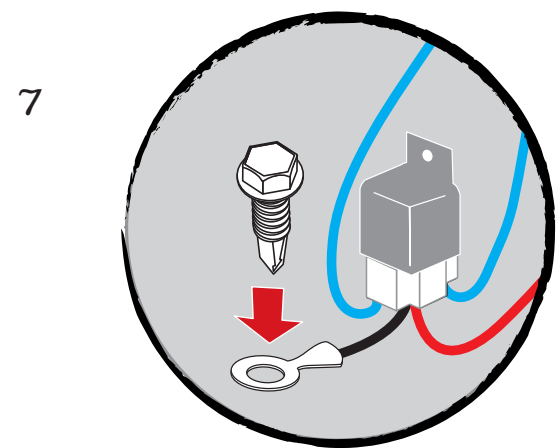

Ground Black.

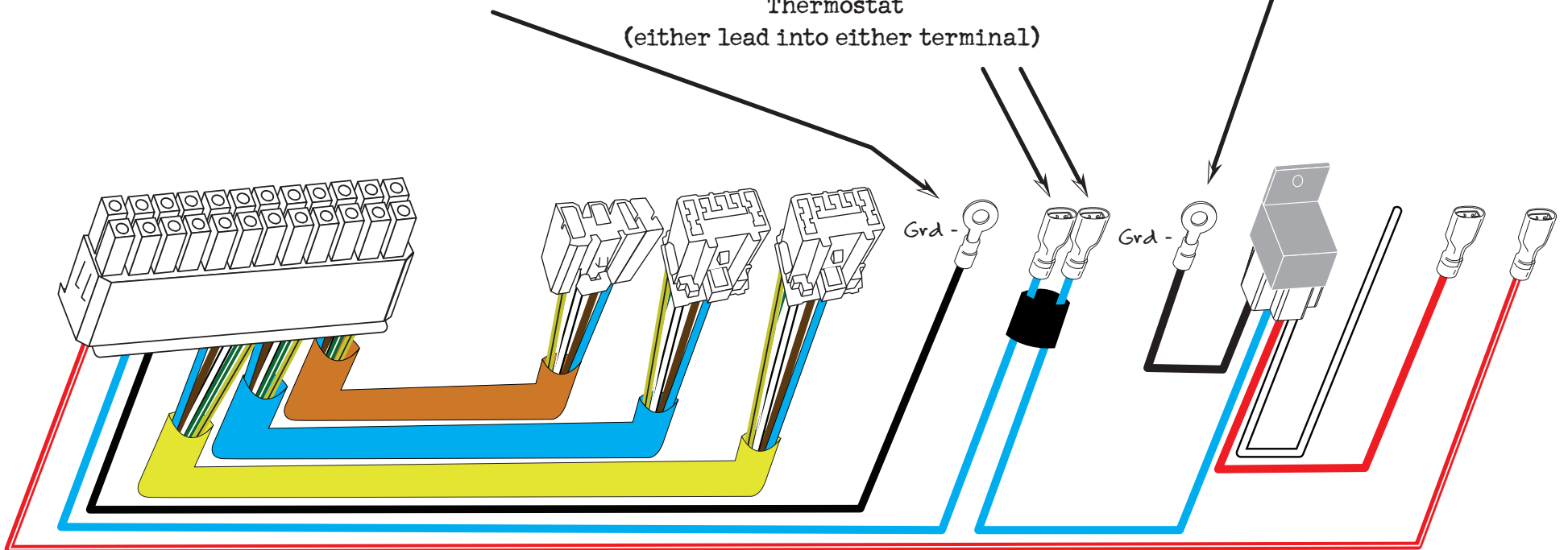

MAIN POWER HARNESS

STEPS 8-10

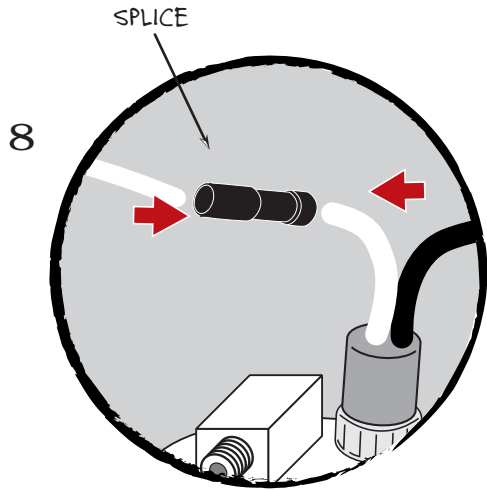

8
 Connect the WHITE leads into the pressure switch (NORMALLY FOUND ON DRIER IN ENGINE COMPARTMENT) on either side and the remaining to your compressor. (either lead into either terminal)

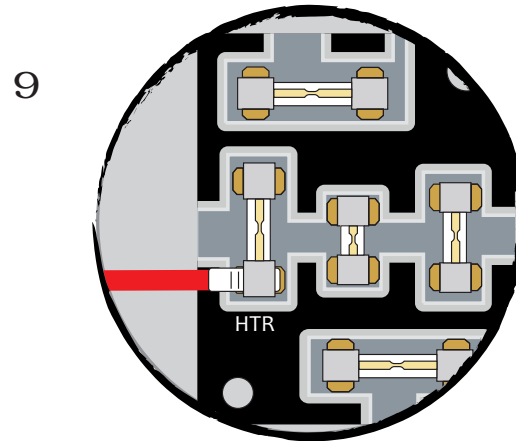

9
 12V Power IGNITION SOURCE (20 amp fuse) (FUSE BLOCK)

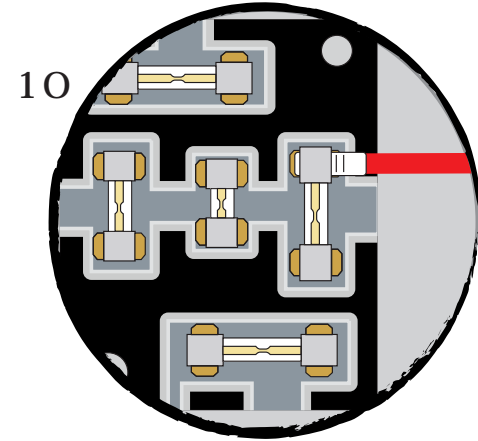

10
 12V Power IGNITION SOURCE (20 amp fuse) (FUSE BLOCK)

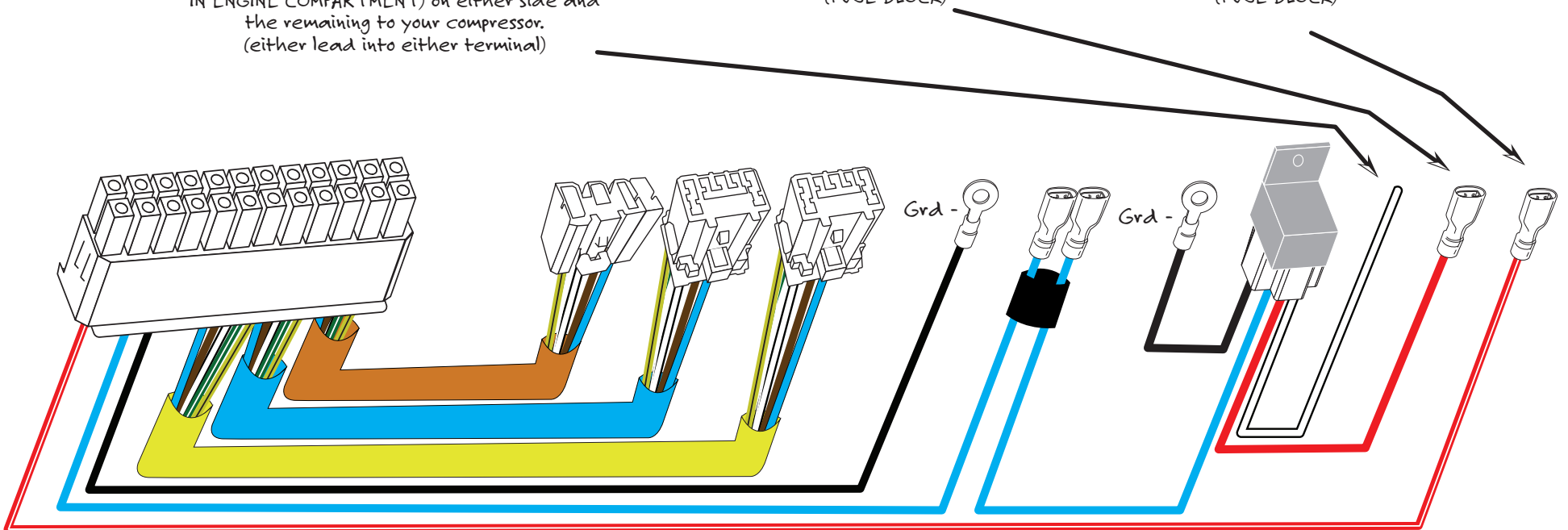

CONNECT BLUETOOTH TO ECU

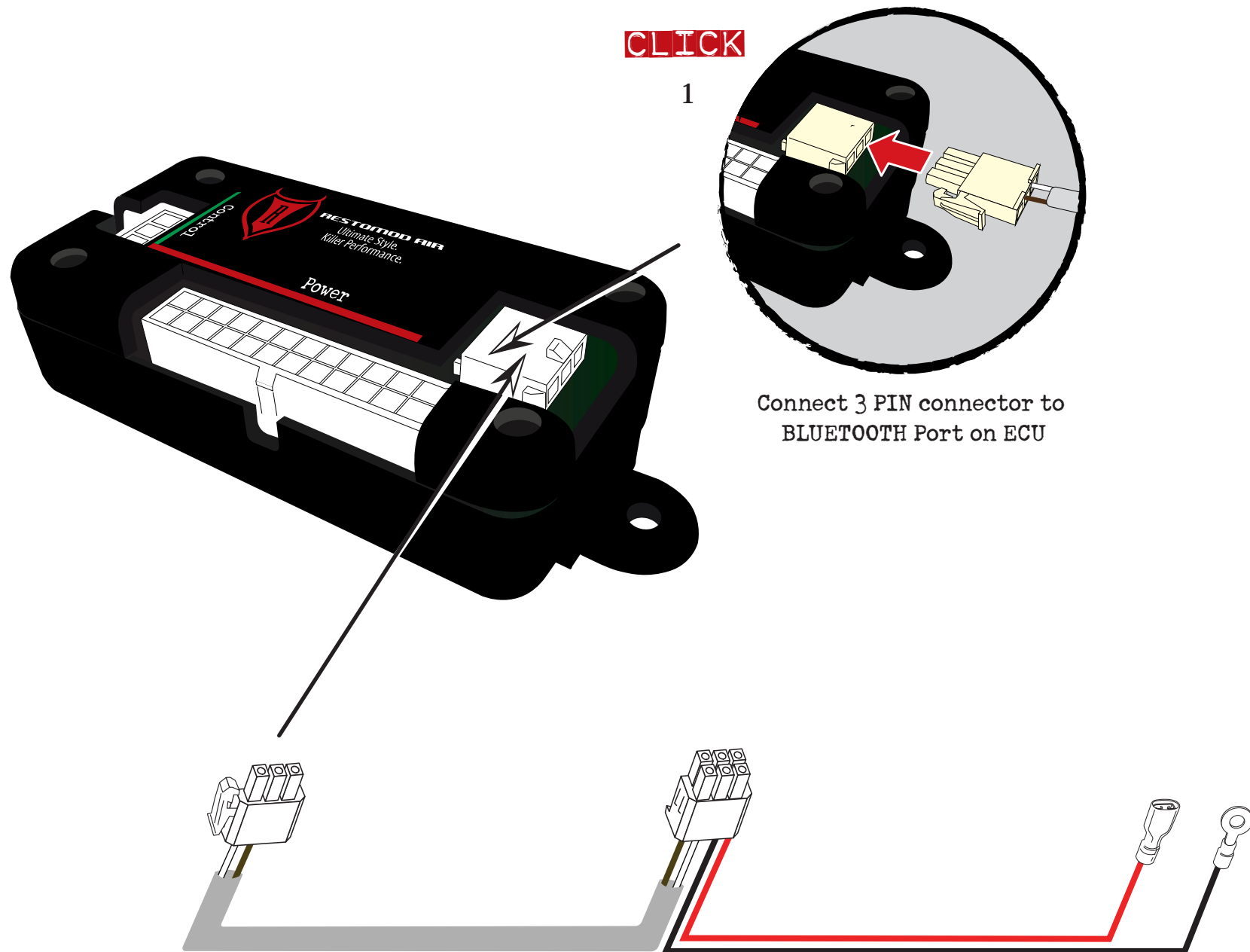

BLUETOOTH HARNESS

STEPS 2-5

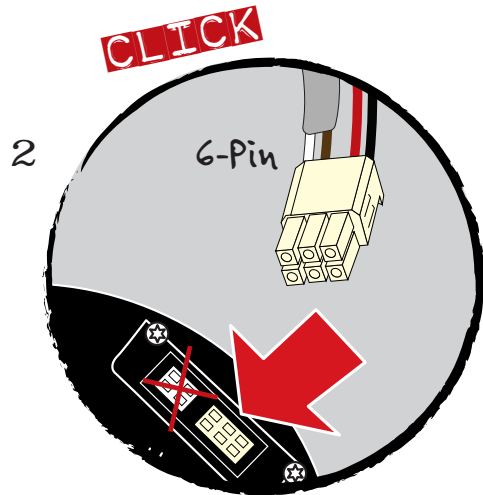

Connect 6 PIN connector
blower motor

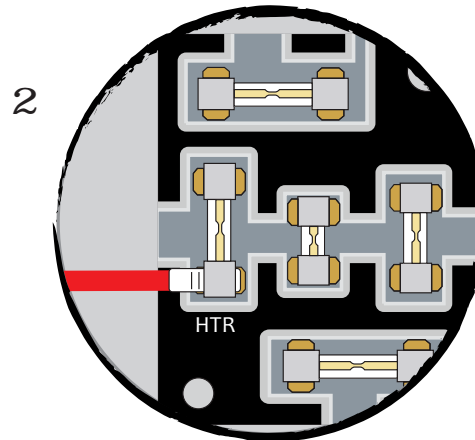

12v Power IGNITION SOURCE
(20 amp fuse)
(FUSE BLOCK)

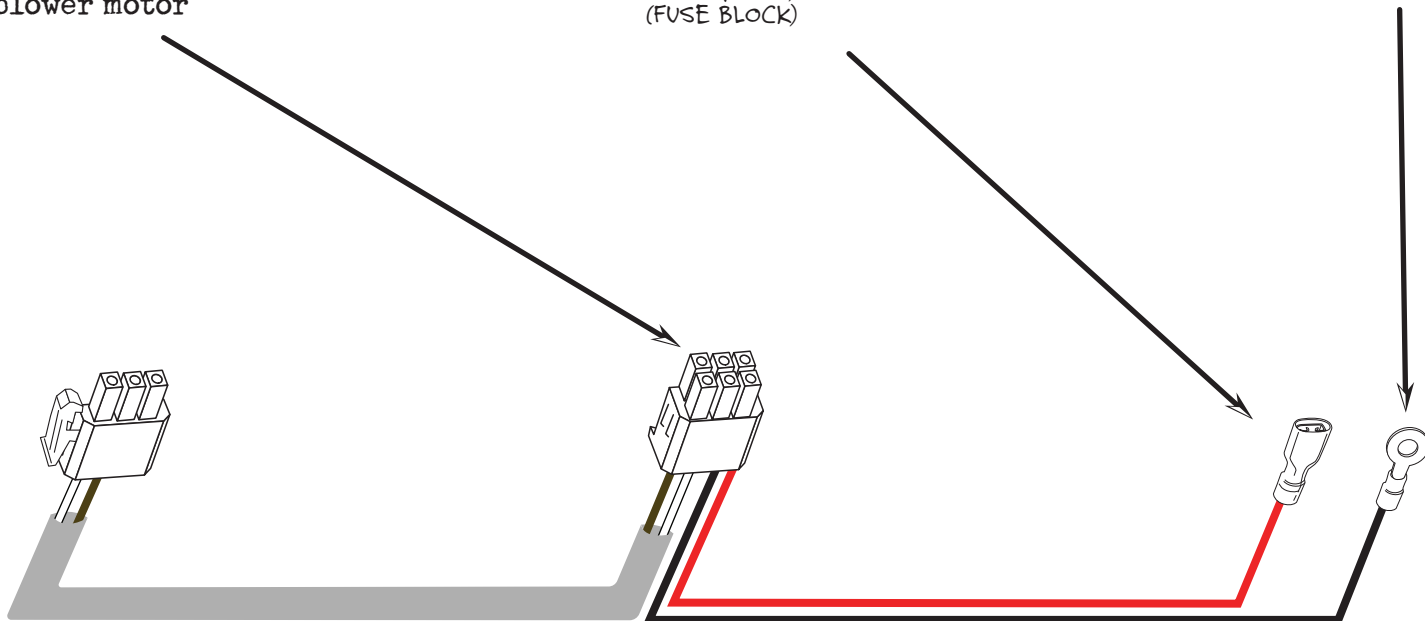
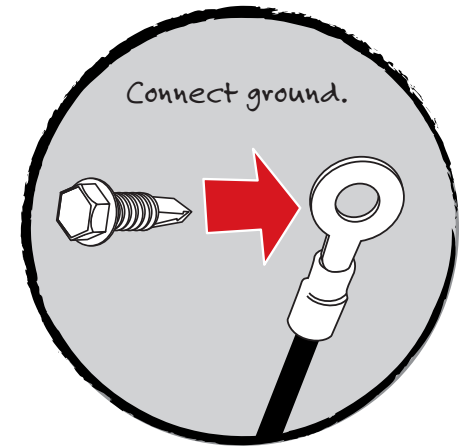

ATMOSPHERE CALIBRATION

1



Launch the Atmosphere App by pressing the Restomod Air logo. (Make certain that you have BLUETOOTH ON.)

**Reference Atmosphere Flowchart for additional troubleshooting.*

2

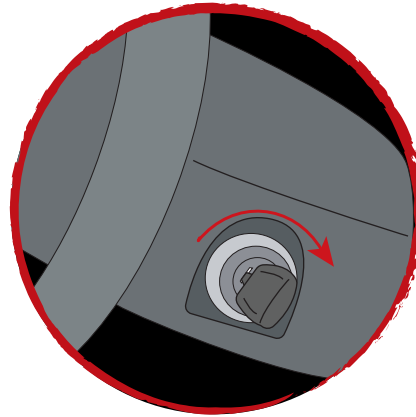

Power Unit
Turn on IGNITION

3

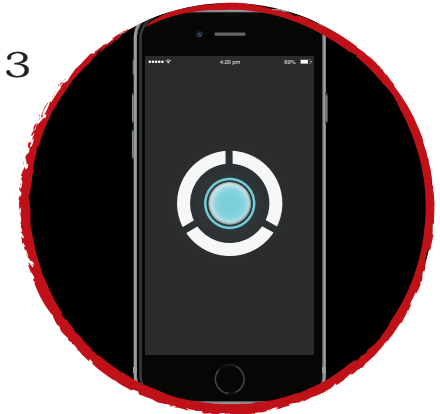

This is your Atmosphere home screen. From here press the center button and hold for 2 seconds. This will take you to the Setting Screen.

4



From this settings screen press Unit Calibrations.

*Note: you will hear the Haymaker
If doors move, your system is
calibrating*

5



Next you will see a pop up window

6



Press the gear on the Settings Screen to go back to the Home Screen.

ATMOSPHERE FAN FUNCTION TEST

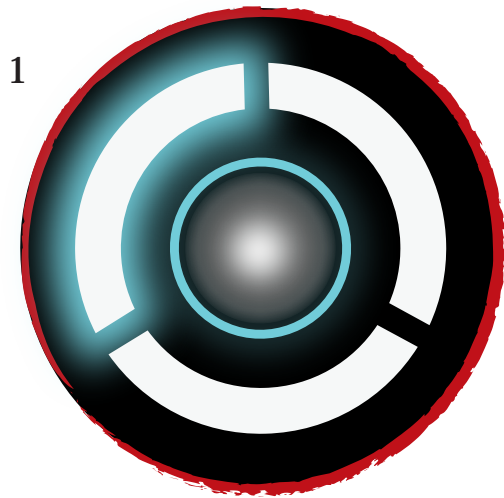

From the Home Screen you can press the LEFT "FAN" button and verify function of your blower motor.

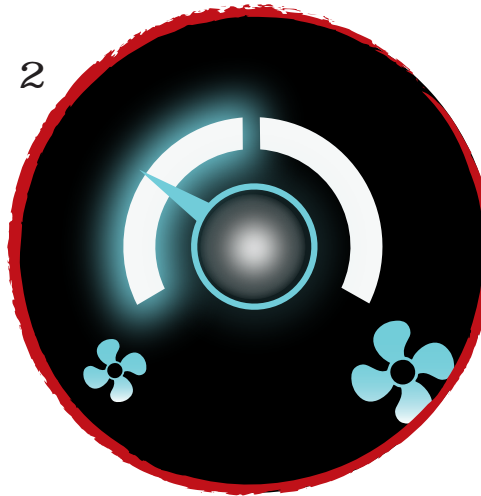

From here you can rotate needle to verify that the blower motor is increasing and decrease speed.

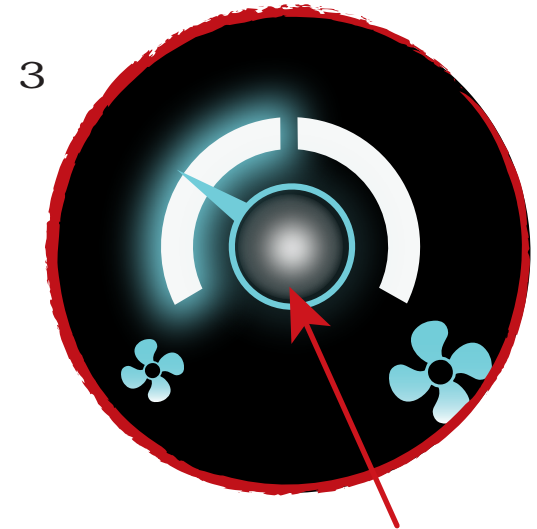

At anytime press the center button to be taken home.

ATMOSPHERE MODE FUNCTION TEST

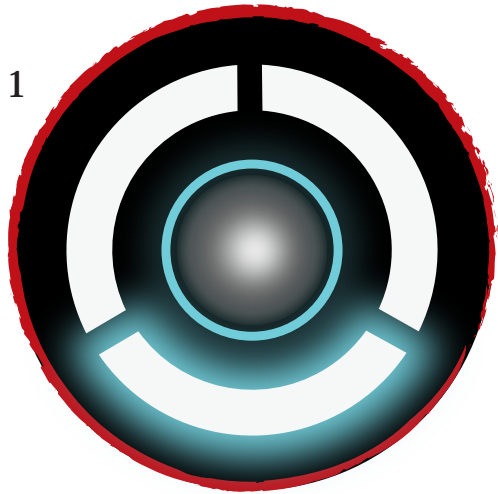

From the Home Screen you can press the LOWER "MODE" button and verify function of your door positions.

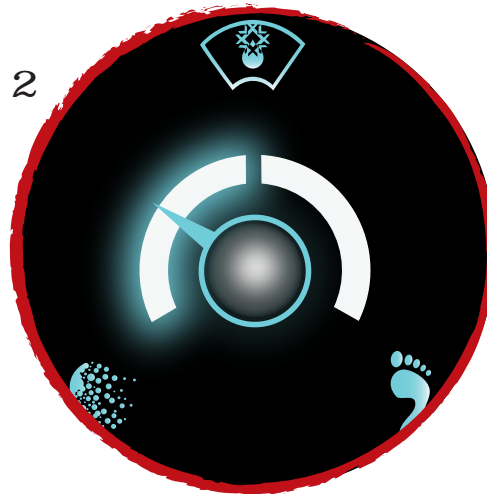

From here you can rotate needle to verify that air is coming out of your Dash, Defrost, Floor.

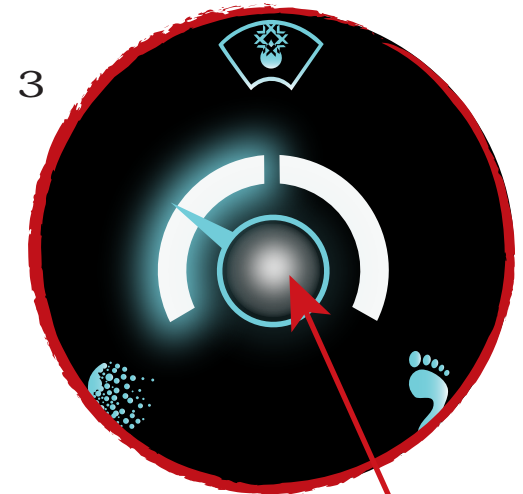

At anytime press the center button to be taken home.

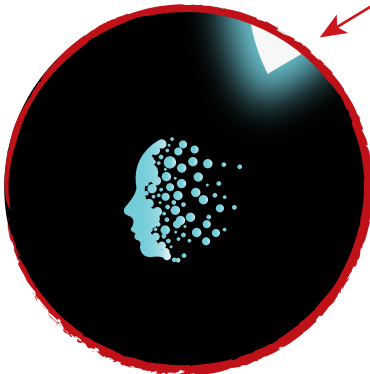

Dash



Defrost



Floor

ATMOSPHERE WATER VALVE FUNCTION TEST

1



From the Home Screen you can press the RIGHT "TEMP" button and verify function of your water valve positions.

2



From here you can rotate needle to verify that water valve is opening and closing.

3



At anytime press the center button to be taken home.

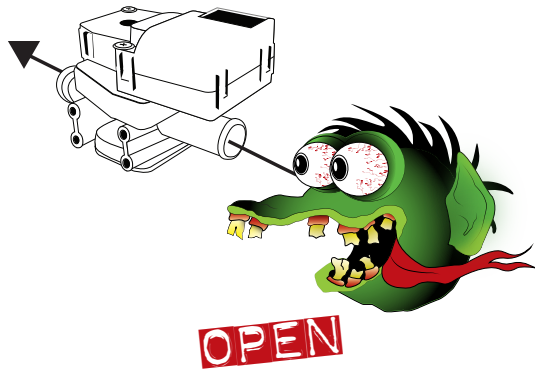

You will be able to see through water valve passage



You will NOT be able to see through water valve passage

ATMOSPHERE SHUT DOWN

NOTE: After each session the App must be RESTARTED



From the Home Screen you press the LEFT "FAN" button.

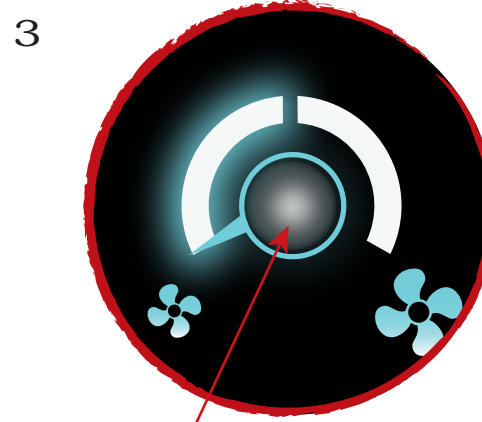

Press the center button to be taken home.

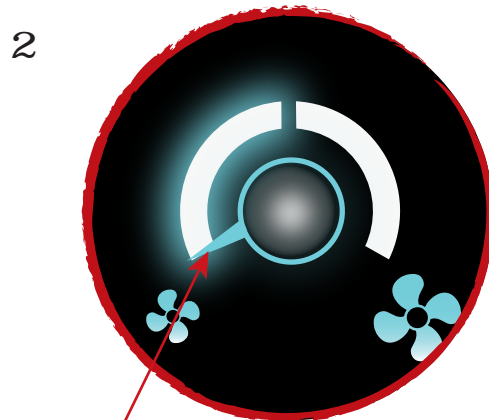

Rotate needle to SMALL FAN ICON This will shut down the blower motor.

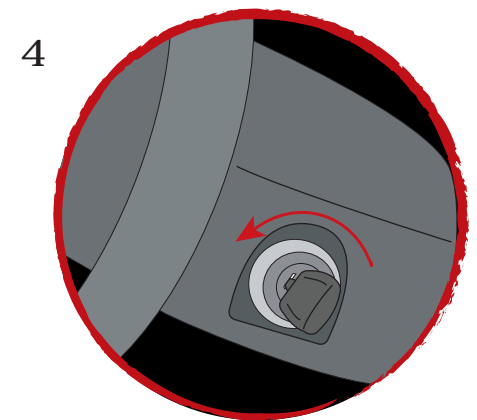

Turn off IGNITION

NOTE: To power OFF the UNIT you must SHUTDOWN the APP. Refer to your IOS/ ANDROID device on proper App shutdown.

ATMOSPHERE MOTOR ERROR

Tips and Tricks

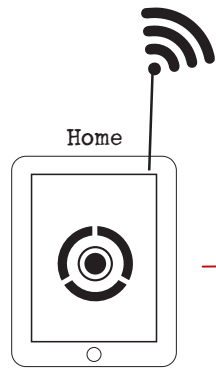

If you are having no response with the blower motor, or changing the mode of your unit. Hold down center dot 2 seconds to be taken to the **SETTINGS** screen.

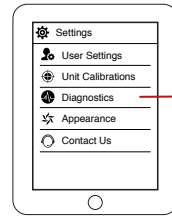

From here click **Diagnostics**.

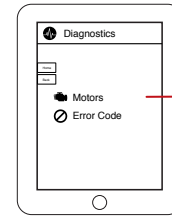

Here you can find out what problem you are having. Clicking on the **Motors** icon will let you know if you have a motor issue.

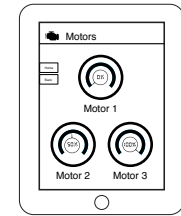

Here you can see the positions of your servo motors. This is useful for troubleshooting a problem. If you are having a motor issue the motor on screen will turn red. Make sure the corresponding cable for the motor is plugged in correctly. From here we will need to do a unit calibration to correct any issue. Afterwards press the **BACK** tab twice to go to **Settings** screen.

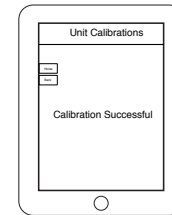

Here is where you need to calibrate your unit after trouble shooting your servo motor. **NOTE** if calibration is unsuccessful you may have to calibrate to 3 times to have everything reset. Press **HOME** tab to return home screen.

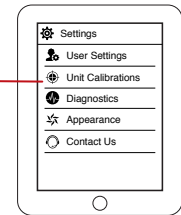

From here click **Unit Calibration**.

ATMOSPHERE FLOWCHART

FAN, MODE, TEMP OPERATIONS

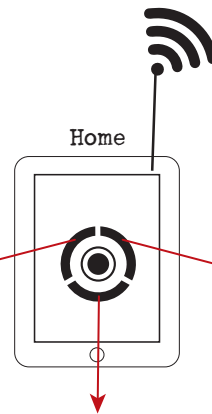

Pressing the LEFT TAB will bring you to the FAN screen. This is where you can control the speed of your unit.

Pressing the LOWER TAB will bring you to the MODE screen. This is where you can control the direction would like your A/C or HEAT to go.

Pressing the RIGHT TAB will bring you to the TEMP screen. This is where you can control how HOT or COLD you want your system to be.

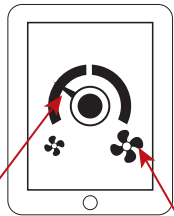

Fan

Tap FAN icons to increase or decrease intensity. You can also grab the needle and rotate to whatever speed you like. At anytime press the center button to be taken HOME.

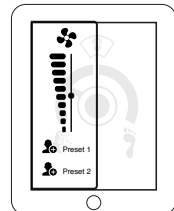

Mode

Notice a shortcut to FAN speed has been built in. At anytime you want to increase/decrease the speed press the side button with the small FAN icon to make and adjustment. Notice this is where you can switch to a Preset User Setting that you create.

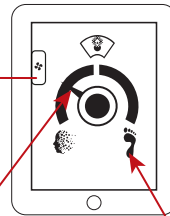

Temp

Tap MODE icons to switch from Dash, Defrost, Floor. You can also grab the needle and blend between. At anytime press the center button to be taken HOME.

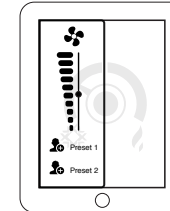

Temp

Notice a shortcut to FAN speed has been built in. At anytime you want to increase/decrease the speed press the side button with the small FAN icon to make and adjustment. Notice this is where you can switch to a Preset User Setting that you create.

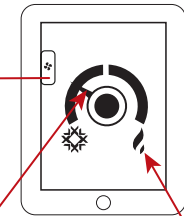

Temp

Tap TEMP icons to switch from Cold, Hot. You can also grab the needle and blend between the two. At anytime press the center button to be taken HOME.

ATMOSPHERE FLOWCHART

USER SETTINGS / UNIT CALIBRATION

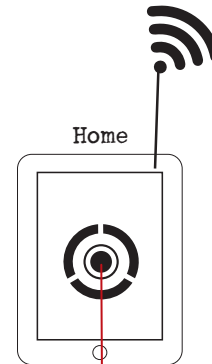

Hold down center dot 2 seconds to be taken to the **SETTINGS** screen. From there you can setup different users, calibrate your unit, diagnose a problem, change the appearance of the app, and contact Restomod Air.

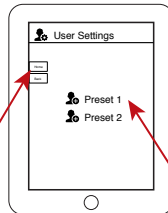

Here you can create two presets for you system. You do this by setting your system up the way you want it and then hold down Preset 1. Do the same for Preset 2. Press **HOME** tab to return home or the **BACK** tab to go to previous screen.

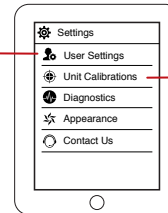

From here you can create a User setting, Calibrate your unit, Diagnose a problem, Change the appearance on the app or contact us. To get back **HOME** from this screen press the Gear icon next to **Settings**.

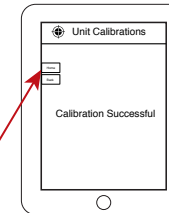

Here is where you setup your unit to communicate with the app. It is an automated setup once pressed. This should only be a one time process. Press **HOME** tab to return home or the **BACK** tab to go to previous screen.

ATMOSPHERE FLOWCHART

DIAGNOSTICS / MOTORS

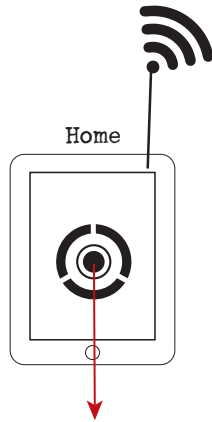

Hold down center dot 2 seconds to be taken to the SETTINGS screen. From there you can setup different users, calibrate your unit, diagnose a problem, change the appearance of the app, and contact Restomod Air.

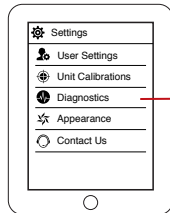

From here you can create a User setting, Calibrate your unit, Diagnose a problem, Change the appearance on the app or contact us. To get back HOME from this screen press the Gear icon next to Settings.

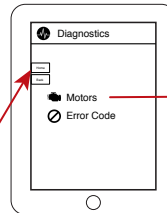

Here you can find out what problem you are having. Press HOME tab to return home or the BACK tab to go to previous screen.

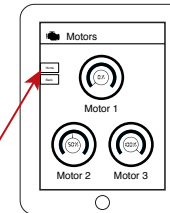

Here you can see the positions of your servo motors. This is useful for troubleshooting a problem. Press HOME tab to return home or the BACK tab to go to previous screen.

ATMOSPHERE FLOWCHART

DIAGNOSTICS / ERROR CODES

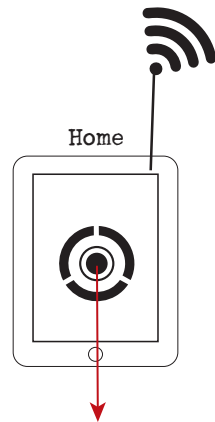

Hold down center dot 2 seconds to be taken to the SETTINGS screen. From there you can setup different users, calibrate your unit, diagnose a problem, change the appearance of the app, and contact Restomod Air.

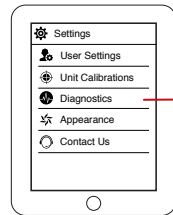

From here you can create a User setting, Calibrate your unit, Diagnose a problem, Change the appearance on the app or contact us. To get back HOME from this screen press the Gear icon next to Settings.

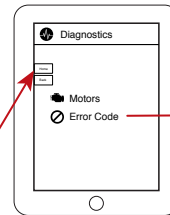

Here you can find out what problem you are having. Press HOME tab to return home or the BACK tab to go to previous screen.

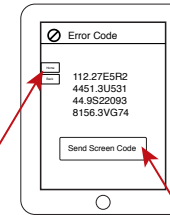

Here you can see an error code and send it directly to a Restomod Air Tech. That code will inform the Tech what problem you are having so you and the Tech can get your system up and running quickly. Press HOME tab to return home or the BACK tab to go to previous screen.

ATMOSPHERE FLOWCHART

APPEARANCE / CONTACT US

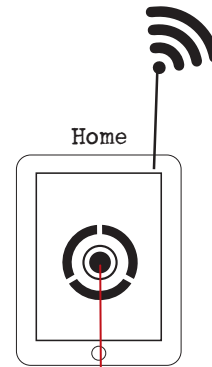

Hold down center dot 2 seconds to be taken to the **SETTINGS** screen. From there you can setup different users, calibrate your unit, diagnose a problem, change the appearance of the app, and contact Restomod Air.



The contact us page is exactly how it sounds. From here you can email a Restomod Air Tech, call us directly, or visit our Facebook page. Press HOME tab to return home or the BACK tab to go to previous screen.

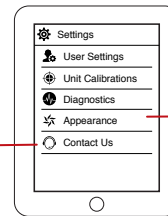

Holding center button for 2 Seconds will take you to the **SETTINGS** screen. From here you can create a User setting, Calibrate your unit, Diagnose a problem, Change the appearance on the app or contact us. To get back HOME from this screen press the Gear icon next to Settings.

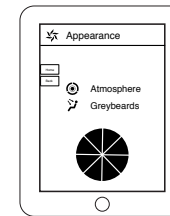

Here you are able to change the look of the app. You can change the color to match your interior and even change the interface of the icons. Greybeards, is a traditional icon look. Atmosphere, is a modern icon look, which is currently set to. You can switch form either one as desired by coming to this screen. Press HOME tab to return home or the BACK tab to go to previous screen.

ATMOSPHERE

Congratulations you have completed setting up the worlds first vehicle climate control app Atmosphere.

You can now wirelessly control your Restomod Air A/C system from any mobile device. Mount your mobile device in dash or not, totally up to you. No cables, no mess, no problem. Totally customizable.



RESTOMOD AIR

Ultimate Style. Killer Performance.

HAYMAKER II-B/T SYSTEM ULTIMATE A/C

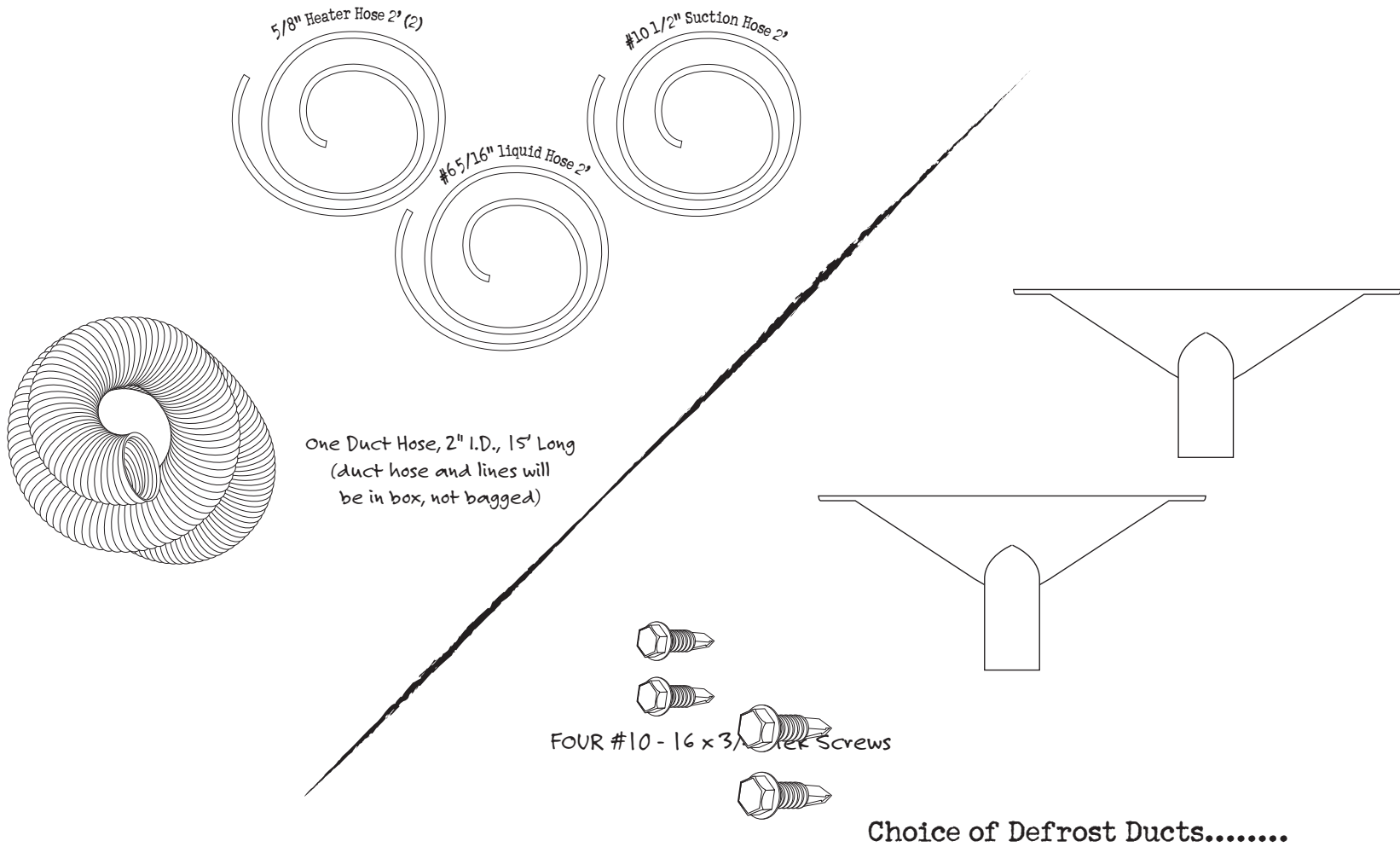

We've included 15' of flex hose for you to route to your choice(s) of main vents and defrost vents. The goal is measure, cut, and install hose sections that will be taunt, but not so tight that the individual lengths will be not have a bit of flexibility. Be sure to keep bends in the flex hoses to a minimum for optimal airflow, and route the hoses so that they will not interfere with any mechanisms.

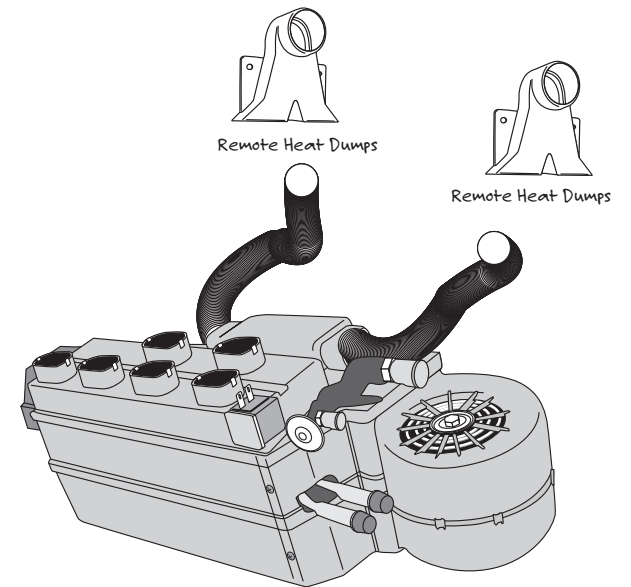
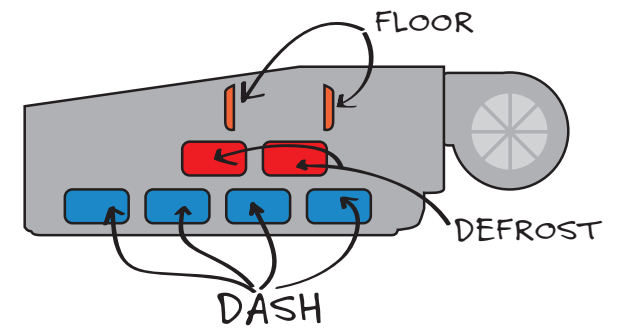
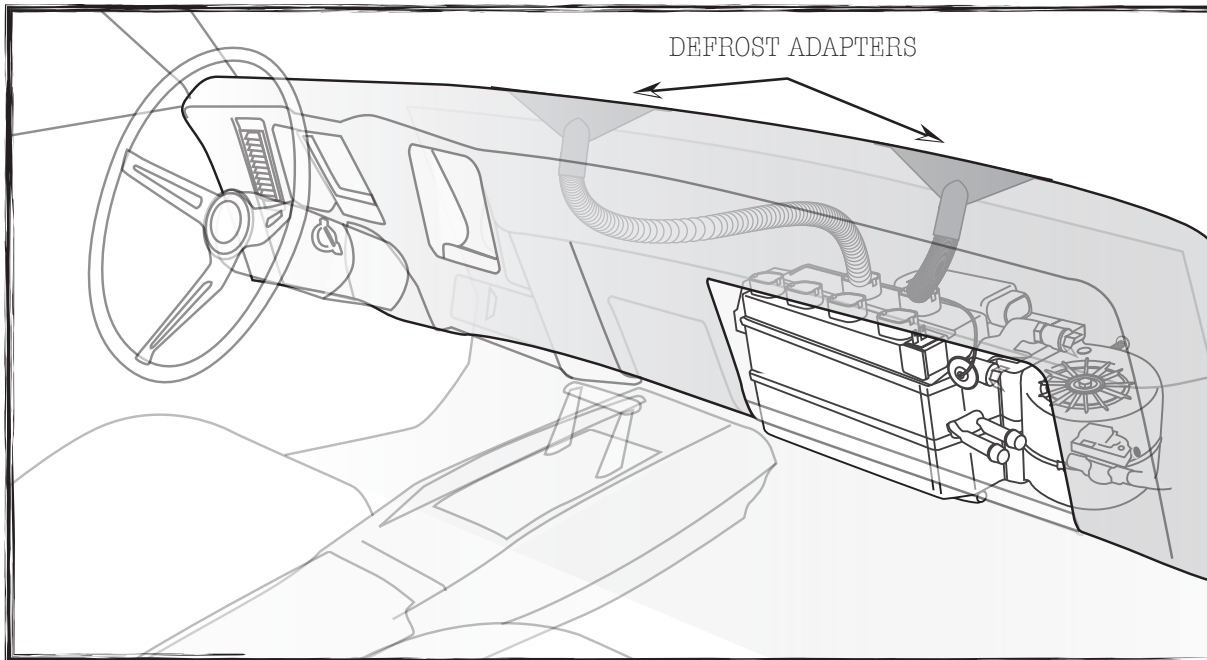

REMOTE MOUNTED HEAT DUMPS

INSTALLING VENTS

Installing Vents, a Quick Primer:

Installing them will go very easily if you plan ahead and take your time. In some cases you may be able to use factory installed vents, if not, follow the following steps:

A: While sitting in the vehicle, make a plan of where the vents will be located, situating them for maximum airflow and convenience. Make sure the location of the vents will not interfere with actions like shifting gears, or that the vents will not be subjected to excessive impact.

B: Many of the vents will require some drilling thru the lower dash to attach. Mark the drill hole(s) location first, and drill pilot holes (i.e. with a small bit like 9/32") before attaching the vents with the included Tek Screws. Also make sure that you don't drill thru wires or other mechanisms when drilling the pilot holes.

C: Some vents can be inserted into OEM vent holes, or you may need to cut-out holes within the

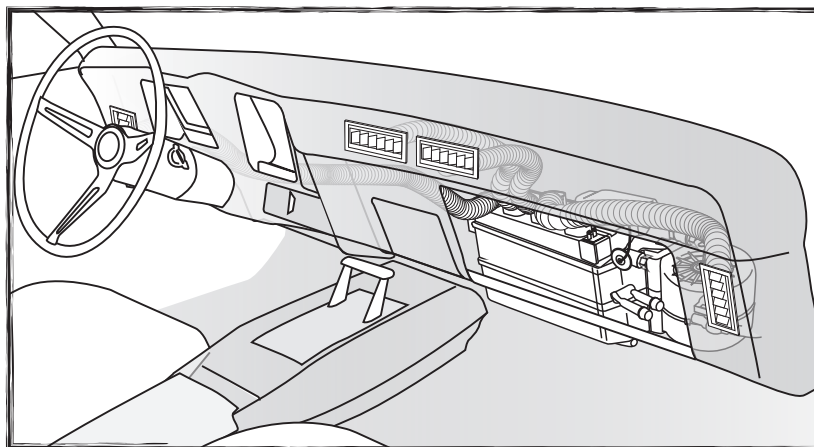

ENGINE COMPARTMENT INSTRUCTIONS

IF YOU HAVE NOT DONE SO ALREADY,
DISCONNECT THE BATTERY.

During the next steps you'll be installing the condenser, drier *, and routing the pressure switch* wire and the A/C lines. Since much of this is installed in the OEM location for the condenser, you'll probably need to remove the center grill section, horn(s), and latch support assembly (see figure 37). Be sure to retain all the mounting screws – you'll reinstall these pieces in the exact reverse order with the OEM screws.

*If Applicable.

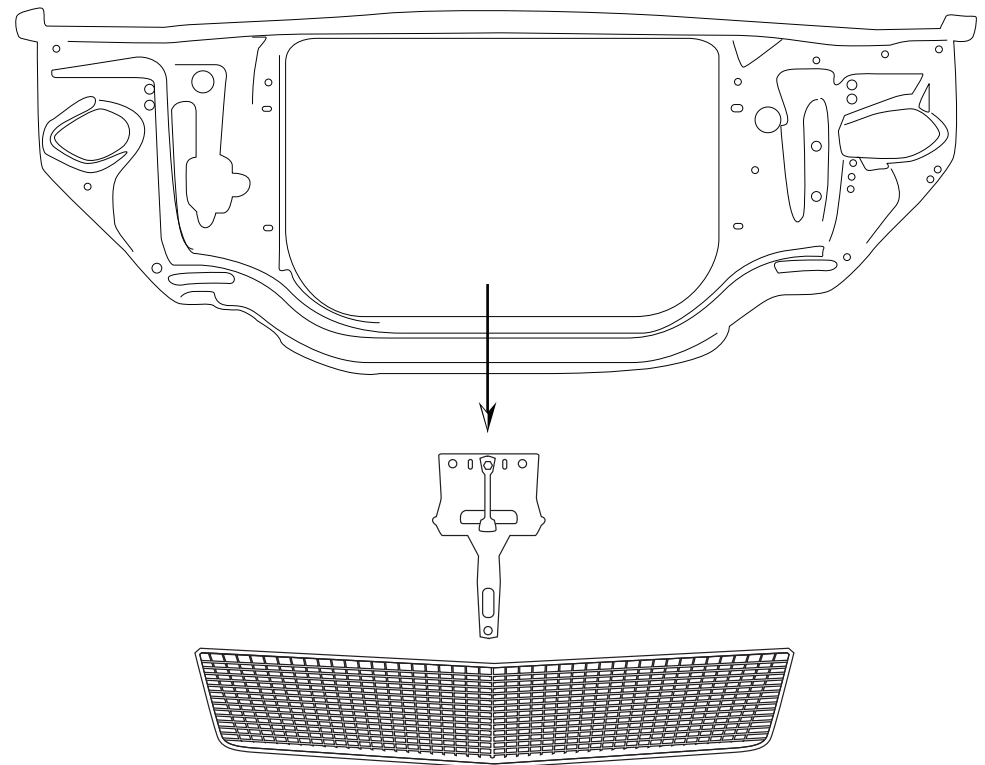
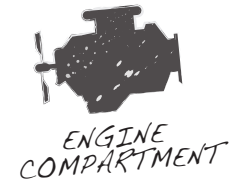

CONDENSER PREP

CONDENSER PREPARATION. Attach brackets using supplied #10-20 x 1/4" HEX HEAD screws to condenser mounting holes found on each side of condenser. The condenser must be mounted to vehicle so that the larger fitting is on top **(FAILURE TO DO SO WILL CAUSE AIR CONDITIONING SYSTEM TO FUNCTION INCORRECTLY).**

DRIER PREPARATION. First insert the drier into the drier mounting bracket (it's basically a sleeve for the drier). Screw the high-pressure switch into the port at the drier. Go ahead and plug the pressure switch harness into the switch at this time (black electrical boot with two long white wires). Mount Drier in preferred location with connections upward. Keep in mind the threaded connection labeled "IN" will connect to the lower connection of condenser.

PRESSURE SWITCH: Install the supplied pressure switch to the port on the top of the drier (Looks like a bolt head). Remove dust cover and attach wiring harness to electrical connections.

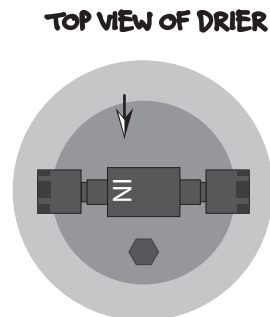
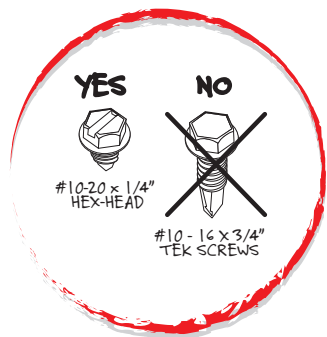

Be sure to mount drier vertically with fittings to top.

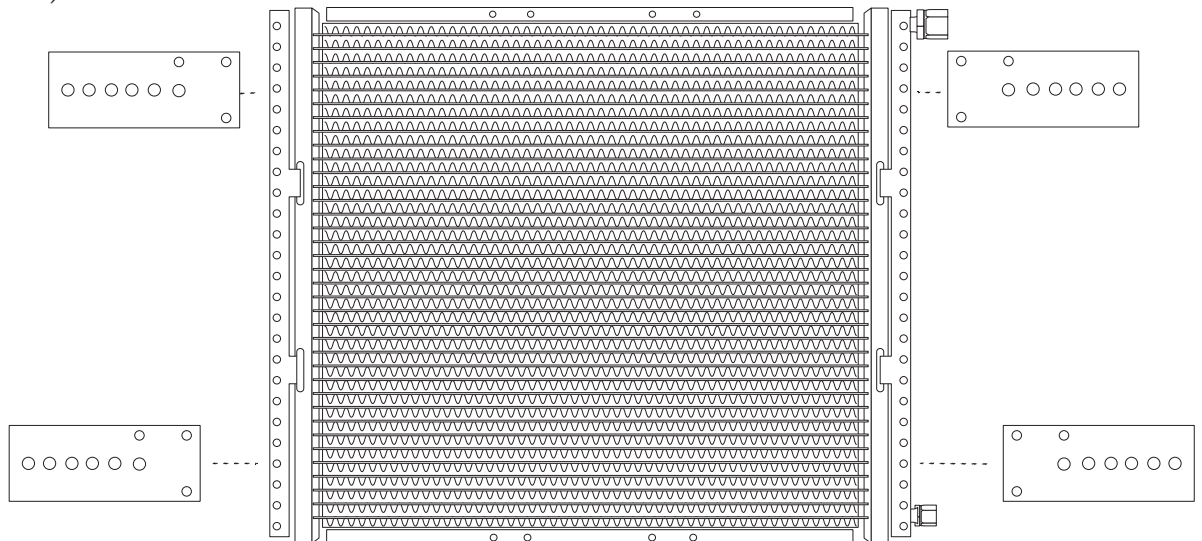

CONDENSER PREP

HAYMAKER II-B/T SYSTEM

ULTIMATE A/C

Place condenser in front of radiator and mount to radiator support with supplied #10-16 x 3/4" TEK screws or desired hardware. Condenser can be mounted with fitting connections to either driver or passenger side. (MAKE CERTAIN LARGE FITTING CONNECTION IS TO THE TOP. FAILURE TO DO SO WILL CAUSE SYSTEM TO FUNCTION INCORRECTLY)

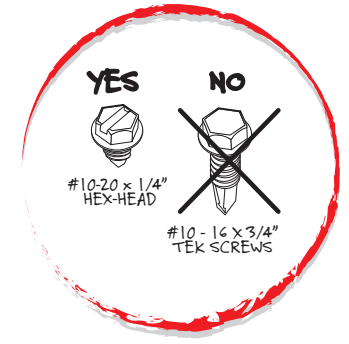
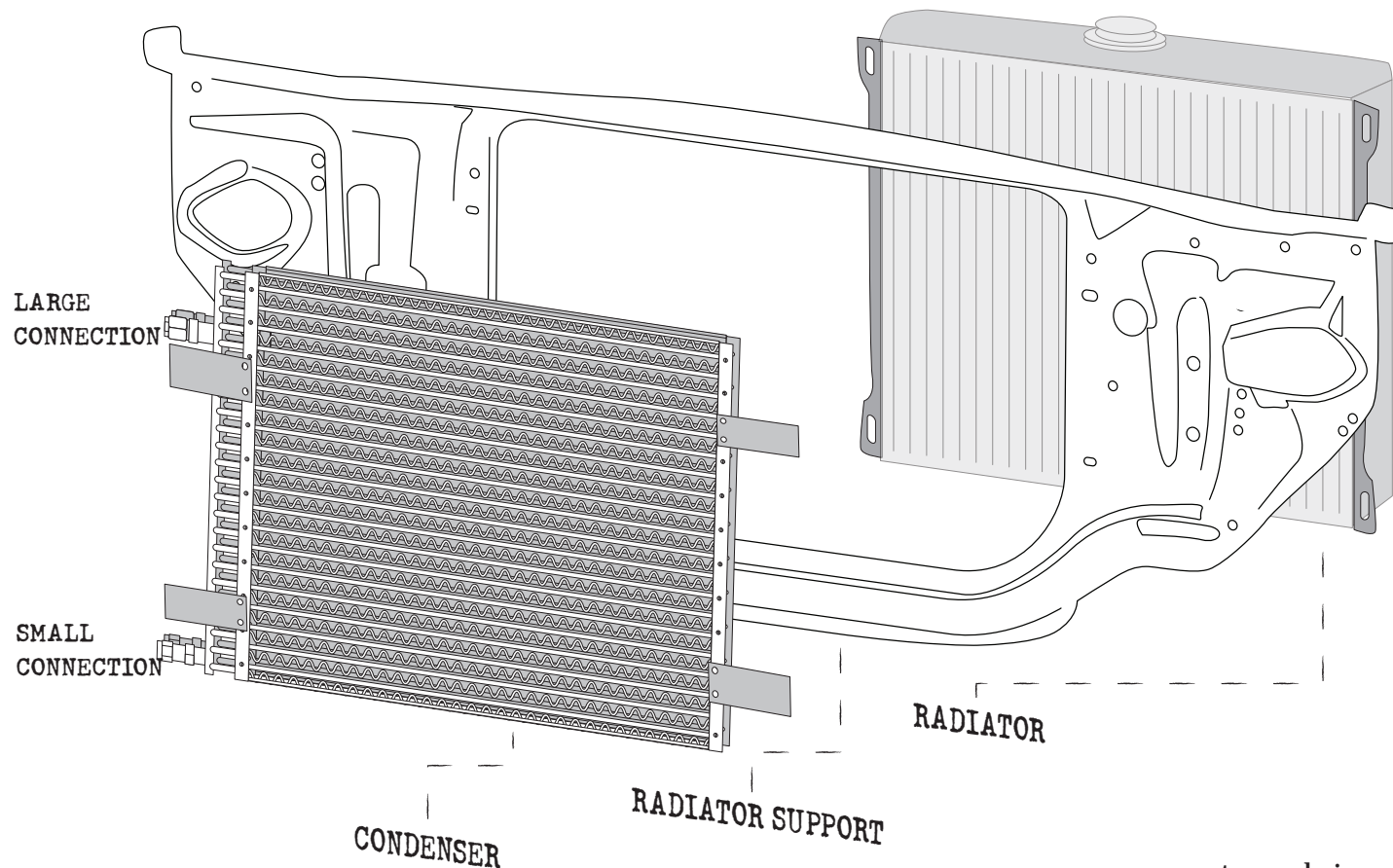

PASSENGER SIDE COMPRESSOR HOSE ROUTING

- A: #6 Liquid Hose (5/16")
- B: #8 Discharge Hose (13/32")
- C: #10 Suction Hose (1/2")

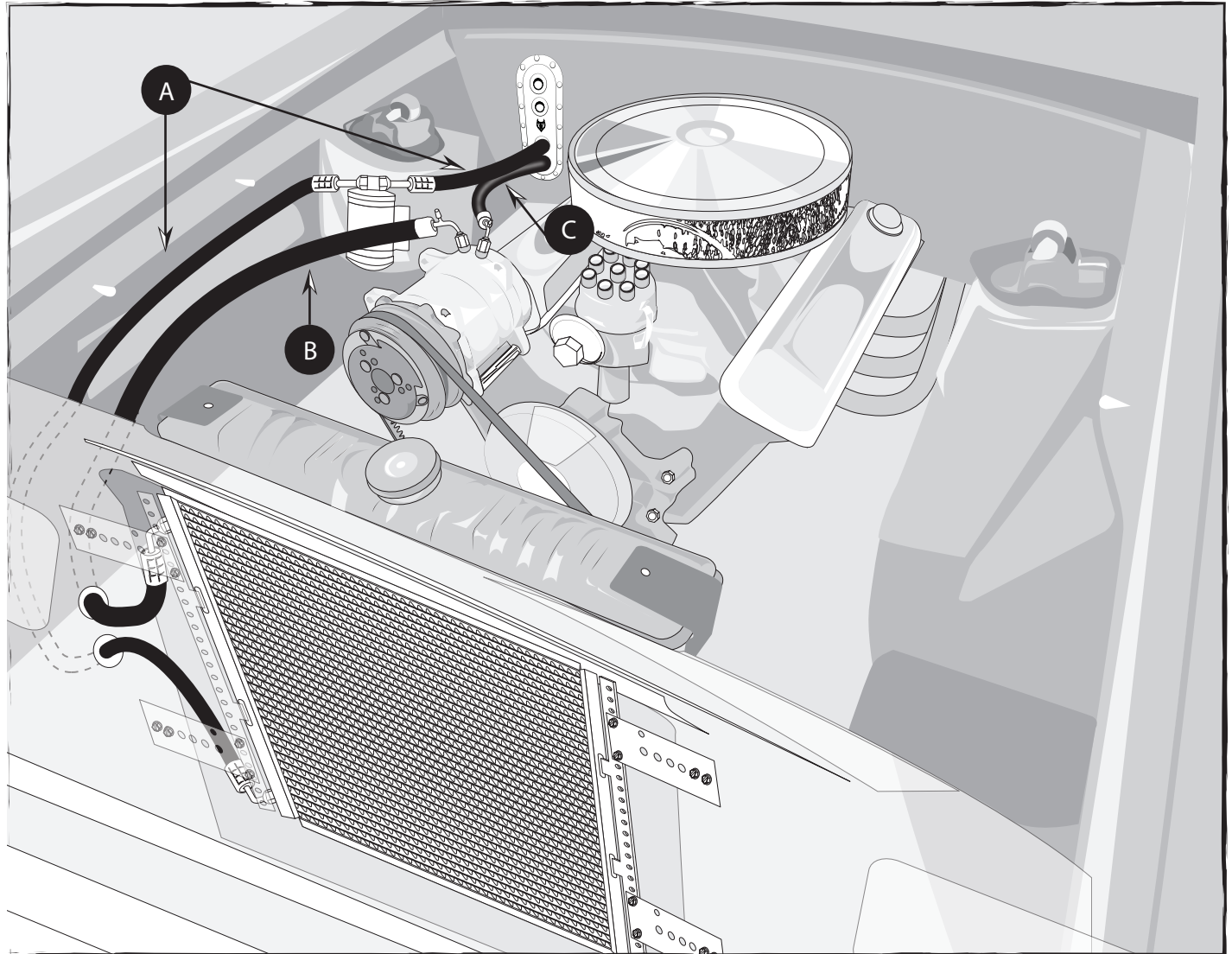

DRIVER SIDE COMPRESSOR HOSE ROUTING

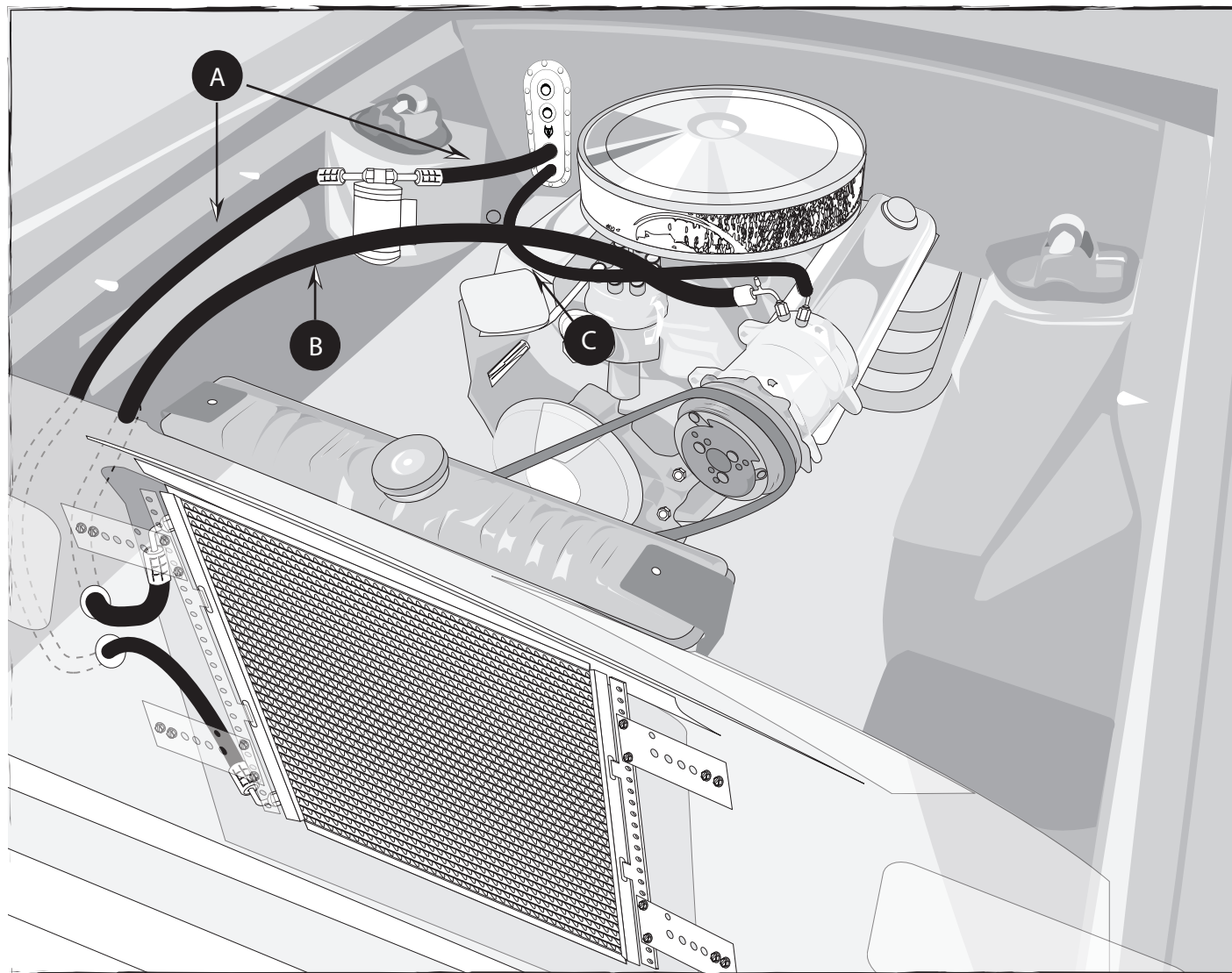

- A: #6 Liquid Hose (5/16")
- B: #8 Discharge Hose (13/32")
- C: #10 Suction Hose (1/2")

*Reminder... Use
two wrenches to
tighten o-ring
fittings*



HAYMAKER II-B/T ULTIMATE A/C SYSTEM

Re-install any components that had to be removed during the installation such as hood latch or grill.

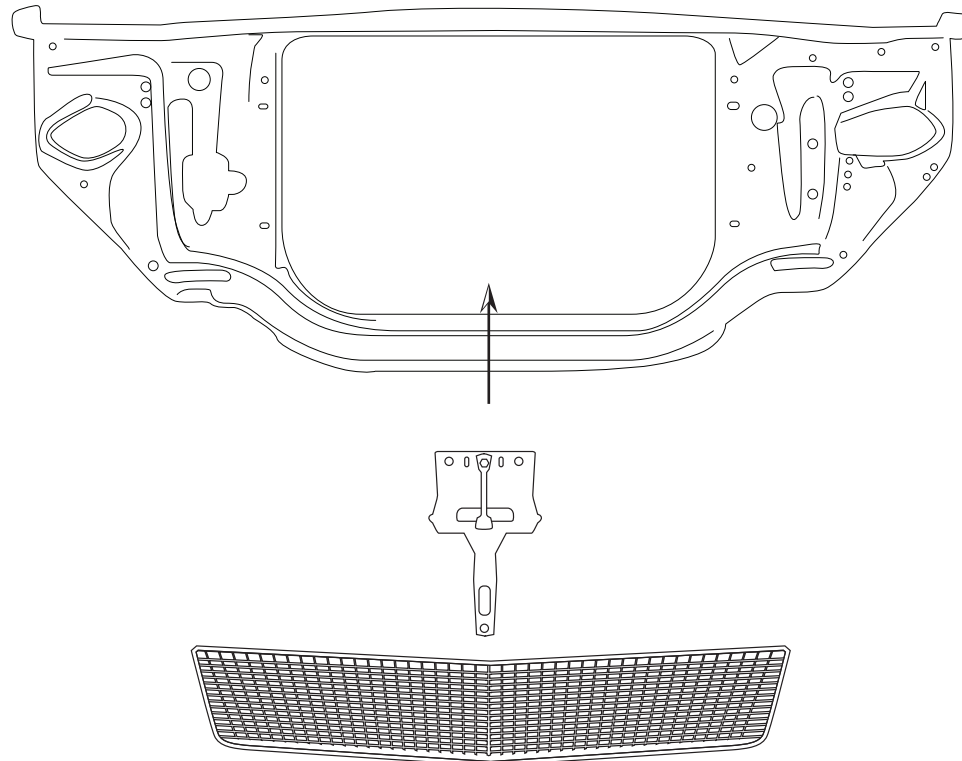

HAYMAKER II-B/T ^{ULTIMATE A/C} SYSTEM

THE FOLLOWING
PAGES ARE CHARGING
INSTRUCTION
PROCEDURES...

REMEMBER,
ALL CHARGING STATIONS CHARGE REFRIGERANT IN
LIQUID FORM, WHICH WILL DAMAGE THE COMPRESSOR IF
IT IS ADDED WHILE THE VEHICLE IS RUNNING

HAYMAKER II-B/T ULTIMATE A/C SYSTEM

CHARGING STATION INSTRUCTIONS

CHARGING PROCEDURES FOR THIS SYSTEM ARE DIFFERENT THAN MOST MODERN A/C SYSTEMS! AVOID DAMAGING YOUR NEW A/C SYSTEM BY CLOSELY FOLLOWING **ALL** THESE GUIDELINES!

WARNING
1

DO NOT CHARGE THIS SYSTEM WITH THE CAR RUNNING!

Unlike the common procedures used for late model vehicles (that have variable-speed compressors), this RETROFIT system cannot be charged with the car running. **THIS IS IMPORTANT...** Failure to follow this warning will most likely result in damaging the compressor and voiding the warranty.

WARNING
2

DO NOT ADD OIL!

All new compressors from Restomod Air contain a full system charge of oil.

WARNING
3

DO NOT USE MORE THAN 24 oz. OF 134a REFRIGERANT!

1.5 lbs. or 24 oz of R134A is what is required.

WARNING
4

HAND TURN THE COMPRESSOR 15-20 TIMES AFTER CHARGING!

Failure to do this may cause the reed valves to become damaged (this damage is NOT covered the warranty).

WARNING
5

BEFORE CHARGING, GO THRU THE CHECK LIST!

HAYMAKER II-B/T ULTIMATE A/C SYSTEM

CHECK LIST: PLEASE READ THRU EACH PROCEDURE BEFORE CHARGING, THEN CHECK OFF EACH ONE IN ORDER.

- Make sure that the new belt is tight.
- Check direction of water valve. The water valve should be connected to the hose going to the water pump.
- Check orientation of compressor. The compressor should not be rotated more than 90° off the centerline of the oil fill plug (during installation or while tightening belt).
- Evacuate the system for a minimum of 30-45 minutes before charging. Longer if possible. This will remove any moisture and reveal any small leaks. Make sure the low-side reaches a minimum of 28-30 inches of vacuum. Failure to evacuate the system will cause inadequate temperatures and premature component failure.
- DO NOT ADD OIL!** All new compressors from Restomod Air contain a full system charge of oil.
- DO NOT CHARGE SYSTEM IN LIQUID FORM.** Unlike later model vehicles, doing so will direct liquid refrigerant into the compressor piston chamber, causing damage to compressor reed valves and/or pistons, as well as potentially seizing the compressor. Doing so voids the warranty.
- This new system requires R134A refrigerant. It will require 1.5 lbs (or 24 oz). **ADDING MORE THAN THE RECOMMENDED AMOUNT OF REFRIGERANT WILL NOT LEAD TO COOLER TEMPS!** No other refrigerant is advisable for our systems. Use of other refrigerants will VOID the warranty.
- This new compressor **MUST** be hand-turned 15-20 revolutions after charging. Failure to do this may cause the reed valves to become damaged (this damage is NOT covered the warranty).

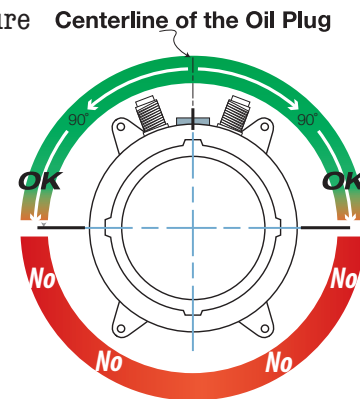
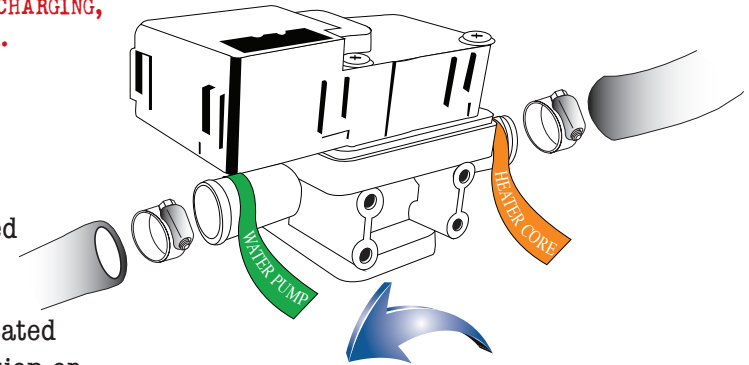

HAND CHARGING INSTRUCTIONS

HAYMAKER II-B/T ULTIMATE A/C SYSTEM

CHARGING PROCEDURES FOR THIS SYSTEM ARE DIFFERENT THAN MOST MODERN A/C SYSTEMS! AVOID DAMAGING YOUR NEW A/C SYSTEM BY CLOSELY FOLLOWING **ALL** THESE GUIDELINES!



DO NOT ADD OIL!

All new compressors from Restomod Air Auto Air contain a full system charge of oil.



DO NOT USE MORE THAN 24 oz. OF 134a REFRIGERANT!

1.5 lbs. or 24 oz of R134A is what is required.



DO NOT SHAKE, TILT, OR TURN CAN UPSIDE DOWN WHILE CHARGING!

Failure to do this may cause the reed valves to become damaged (this damage is NOT covered the warranty). Refrigerant must come out of the top of the can.

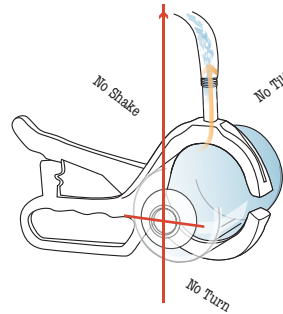

BEFORE CHARGING, GO THRU THE CHECK LIST!

THE RESULTS

TEST CONDITIONS

(After system has been fully charged and tested for basic operation)

- Determine the temperature outside of the car
- Close all doors and windows on vehicle
- Place shop fan directly in front of condenser
- Connect gauges or service equipment to high/low charging ports
- Place blower fan switch on medium
- Run engine idle up to approx. 1500 rpm

DATE

OUTSIDE
TEMP

HIGH-SIDE PRESSURE
READING (AT ENGINE IDLE)
TARGET (150-250 PSI)

LOW-SIDE PRESSURE
READING (AT ENGINE IDLE)
TARGET (15-25 PSI in a steady state)

NOTES

TECHNICIAN NAME AND SIGNATURE

HAYMAKER II-B/T **ULTIMATE A/C** SYSTEM

TROUBLESHOOTING GUIDE

TEST CONDITIONS USED TO DETERMINE SYSTEM OPERATION

(THESE TEST CONDITIONS WILL SIMULATE THE AFFECT OF DRIVING THE VEHICLE AND GIVE THE TECHNICIAN THE THREE CRITICAL READINGS THAT THEY WILL NEED TO DIAGNOSE ANY POTENTIAL PROBLEMS).

- B. CONNECT GAUGES OR SERVICE EQUIPMENT TO HIGH/LOW CHARGING PORTS.
- C. PLACE BLOWER FAN SWITCH ON MEDIUM.
- D. CLOSE ALL DOORS AND WINDOWS ON VEHICLE.
- E. PLACE SHOP FAN IN FRONT OF CONDENSER.
- F. RUN ENGINE IDLE UP TO 1500 RPM.

ACCEPTABLE OPERATING PRESSURE RANGES (R134A TYPE)

- 1. HIGH-SIDE PRESSURES (150-250 PSI) **Note- general rule of thumb is two times the ambient (daytime) temperature, plus 15-20%.*
- 2. LOW-SIDE PRESSURES (15-25 PSI in a steady state).

CHARGE AS FOLLOWS: R134A = 24 OZ.

NO ADDITIONAL OIL IS NECESSARY IN OUR NEW COMPRESSORS.

TYPICAL PROBLEMS ENCOUNTERED IN CHARGING SYSTEMS

NOISY COMPRESSOR. A noisy compressor is generally caused by charging a compressor with liquid or overcharging

- A. If the system is overcharged both gauges will read abnormally high readings. This is causing a feedback pressure on the compressor causing it to rattle or shake from the increased cylinder head pressures. System must be evacuated and re-charged to exact weight specifications.
- B. **Heater control valve installation** - Installing the heater control valve in the incorrect hose. Usually when this occurs the system will cool at idle then start to warm up when raising the RPM's of the motor. **THE HEATER CONTROL IS A DIRECTIONAL VALVE; MAKE SURE THE WATER FLOW IS WITH THE DIRECTION OF THE ARROW.** As the engine heats up that water transfers the heat to the coil, thus overpowering the a/c coil. A leaking or faulty valve will

have a more pronounced affect on the unit's cooling ability. Installing the valve improperly (such as having the flow reversed) will also allow water to flow through, thus inhibiting cooling. Check for heat transfer by disconnecting hoses from the system completely. By running down the road with the hoses looped backed through the motor, you eliminate the possibility of heat transfer to the unit.

- C. **Evaporator freezing** - Freezing can occur both externally and internally on an evaporator core. External freeze up occurs when the coil cannot effectively displace the condensation on the outside fins and the water forms ice (the evaporator core resembles a block of solid ice), it restricts the flow of air that can pass through it, which gives the illusion of the air not functioning. The common cause of external freezing is the setting of the thermostat and the presence of high humidity in the passenger compartment. All door and window seals should be checked in the event of constant freeze-up. A thermostat is provided with all units to control the cycling of the compressor.
- D. **Internal freeze up** occurs when there is too much moisture inside the system. The symptoms of internal freeze up often surface after extended highway driving. The volume of air stays constant, but the temperature of the air gradually rises. When this freezing occurs the low side pressure will drop, eventually going into a vacuum. At this point, the system should be checked by a professional who will evacuate the system and the drier will have to be changed.
- E. **Inadequate airflow to condenser** - The condenser works best in front of the radiator with a large supply of fresh air. Abnormally high pressures will result from improper airflow. Check the airflow requirements by placing a large capacity fan in front of the condenser and running cool water over the surface. If the pressures drop significantly, this will indicate the need for better airflow.
- F. **Incorrect or inadequate condenser capacity** - Incorrect condenser capacity will cause abnormally high head pressures. A quick test that can be performed is to run cool water over the condenser while the system is operating, if the pressures decrease significantly, it is likely a airflow or capacity problem.
- G. **Expansion valve failure** - An expansion valve failure is generally caused by dirt or debris entering the system during assembly. If an expansion valve fails it will be indicated by abnormal gauge readings. A valve that is blocked will be indicated by high side that is unusually high, while the low side will be unusually low or may even go into a vacuum. A valve that is stuck open will be indicated by both the high and low pressures rising to unusually high readings, seeming to move toward equal readings on the gauges.
- H. **Restrictions in system** - A restriction in the cooling system will cause abnormal readings on the gauges. A high-side restriction (between the compressor and the drier inlet) will be indicated by the discharge gauges reading excessively high. These simple tests can be performed by a local shop and can help determine the extent of the systems problem.

HAYMAKER II-B/T SYSTEM ULTIMATE A/C

Trouble Shooting Your Restomod Air A/C System

PROBLEM: system is not cooling properly
ISSUE: cold at idle, warmer when raising engine RPM's

Make sure the Water Valve is positioned correctly

The water valve is a directional valve and should be installed with the arrow pointing towards the water pump, it should be connected to the heater hose that runs from the heater core to the water pump. If the water valve is connected to the incorrect hose it allows water to circulate through the system via the heater core over powering the cooling effect of the A/C coil, (normally the air conditioning is functioning properly).

Step 1: Check placement of the water valve, correct if needed. (In some cases changing the location of the water valve may not fix the above problem.) Continue to next step.

Step 2 If changing the location of the water valve does not rectify the issue, then possibly the water valve is permanently damaged and may need to be replaced. To check the integrity of the water valve completely remove the water hoses for the heater core and "loop" together. (This will remove the heater system completely from the possibilities) If the system now cools, replace the water valve

Verify Adequate Air Flow to Condenser

For an air conditioning system to function properly there has to be adequate airflow across the condenser. The function of the condenser is to dissipate heat, without proper airflow your system will not cool correctly in the cabin of your vehicle.

Step 1: connect gauges to a/c hoses. The pressures should be: with the ambient temp is 90, low side pressures should be between 15-25 psi, high side pressures should be between 150-250 psi

Step 2: IF the low side pressures are normal and the high side pressures are high then there might be an airflow issue, continue to next step.

To test air flow to Condenser do the following three tests:

1. Place a piece of paper on the condenser with the car in idle and see if paper is held in place.
2. With car in idle, attach gages, and place a large capacity fan in front of the condenser. What happens to the pressures?
3. With car still in idle and gages attached, pour water down the front of the condenser. What happens to the pressures?

If the paper is held in place you are at least getting some air flow. If the high side decreases during test 2 & 3 then your condenser is not getting enough air which is causing your system to not cool properly. To correct this issue you will need a more powerful mechanical fan.

Step 3: Confirm correct Refrigerant charge in System

All of our systems should be charged with 24 oz or 1.8 lbs of R134A Refrigerant only. If overcharged you will need to evacuate the system and recharge with the correct amount.*

What measurements mean:

Low Temp and High Pressure seem to be equal...

You have a malfunctioning expansion valve that is stuck open.

High Side is extremely high and Low Side is extremely low (possibly into vacuum)...

There is a blockage in the system. Remove hoses and blow compressed air through in both directions. If pressures don't change its possible that your expansion valve is stuck closed and would have to be replaced.

***Compressor Concerns:**

This is often misdiagnosed as a problem for the system not cooling properly. If you have a noisy compressor it is due to improper charging of refrigerant. An overcharged (more than 24 oz or 1.5 lbs R134A) compressor can cause rattling. If charged with pure liquid there is a high probability you have bent reed valves that are causing tapping sound.

WIRING SCHEMATIC

MAIN POWER HARNESS

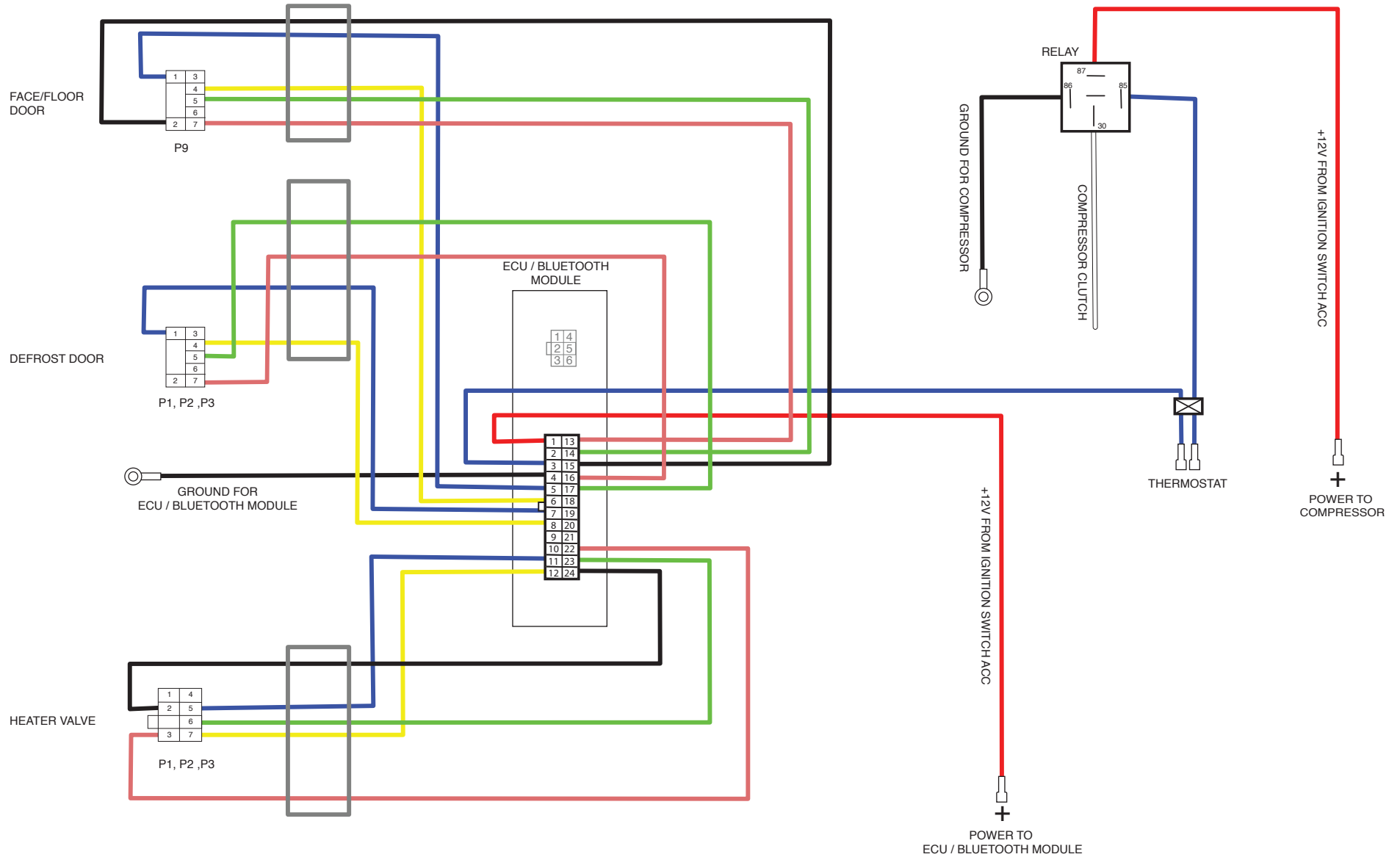

WIRING SCHEMATIC

BLUETOOTH HARNESS

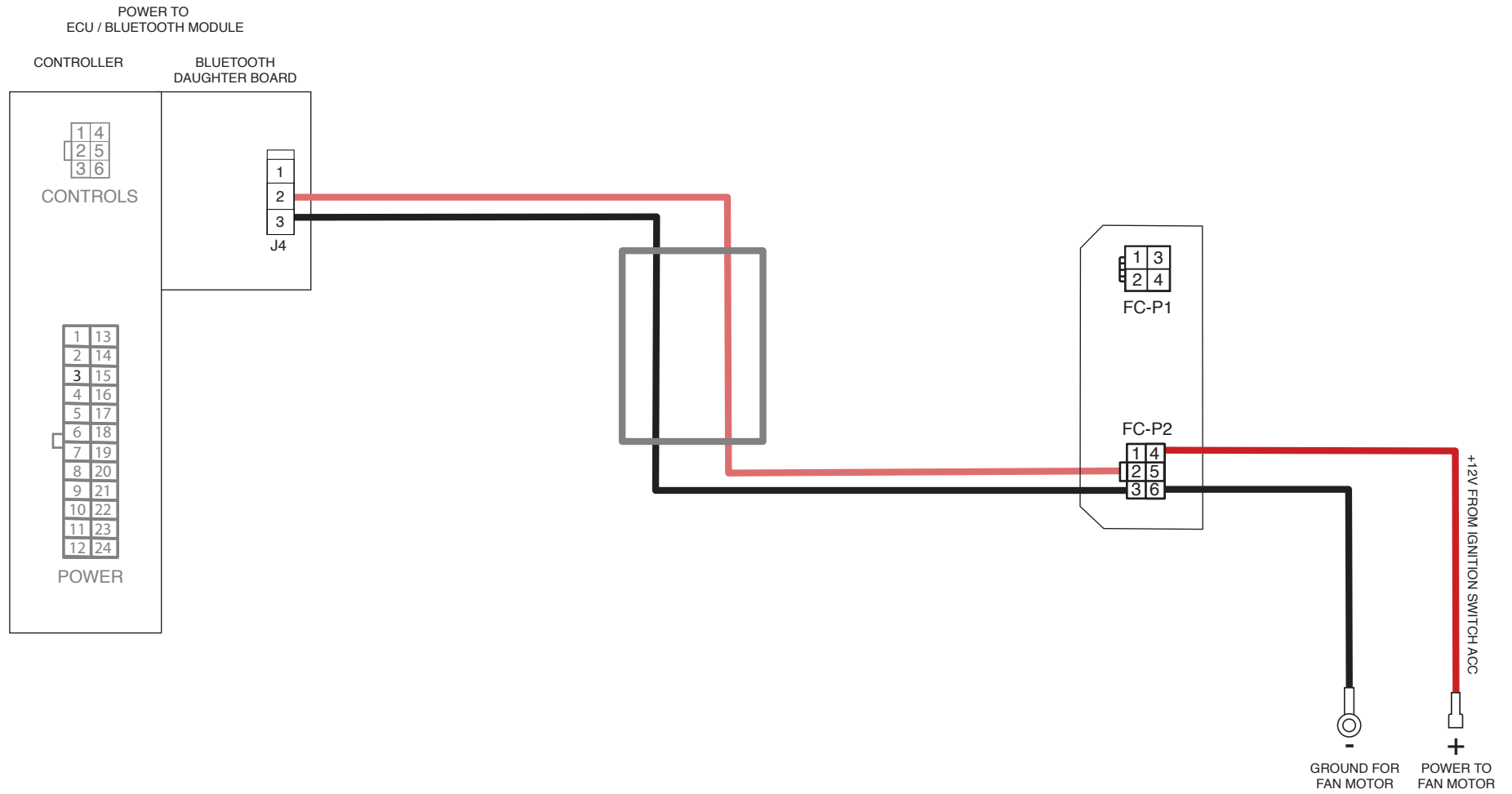

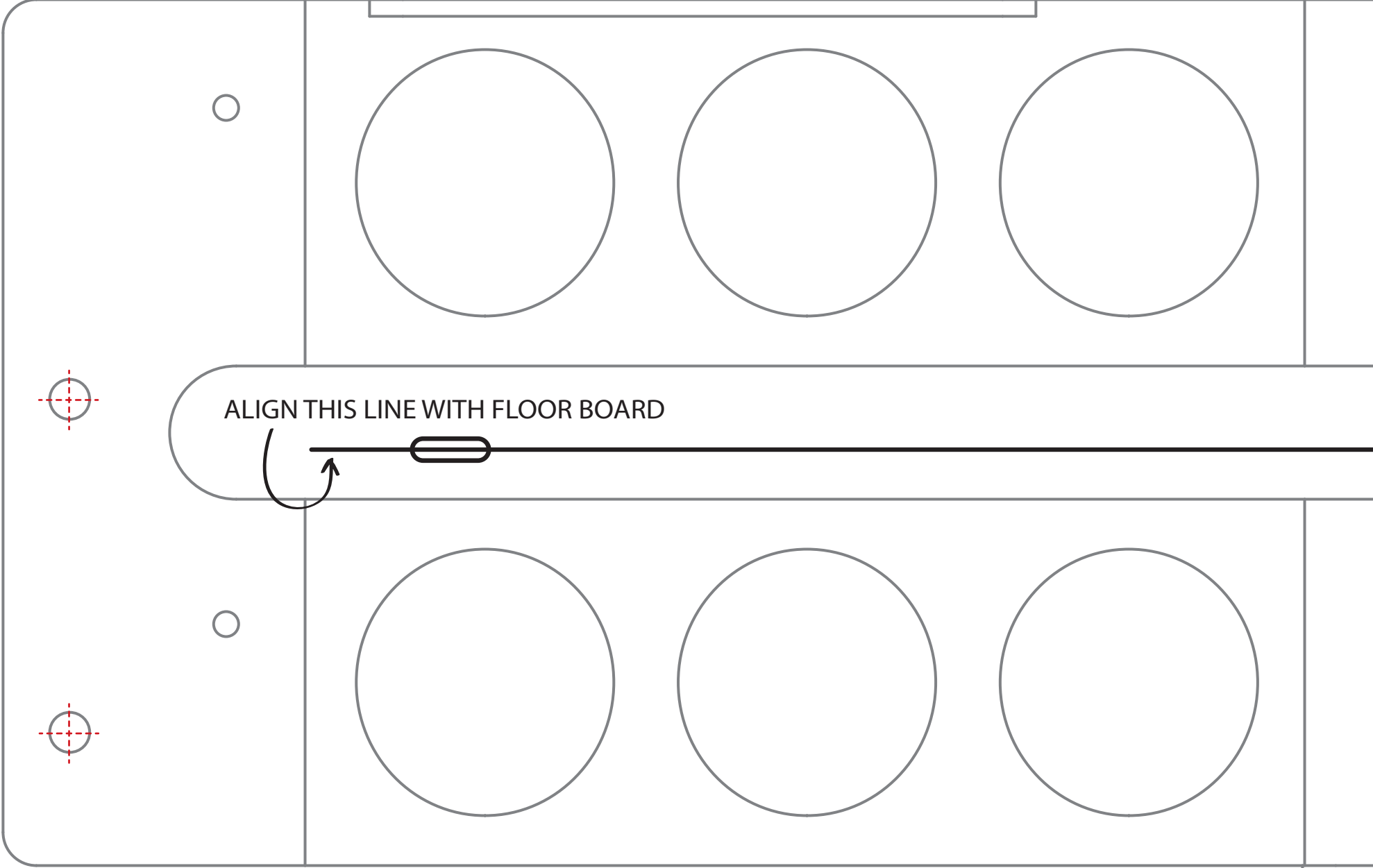

**IF YOU PRINTED THIS MANUAL
PLEASE READ THIS...**
Just as a cautionary step, please
measure this box and make sure it
is 1" x 1". Some copiers/printers
may not print at 100% of actual size.



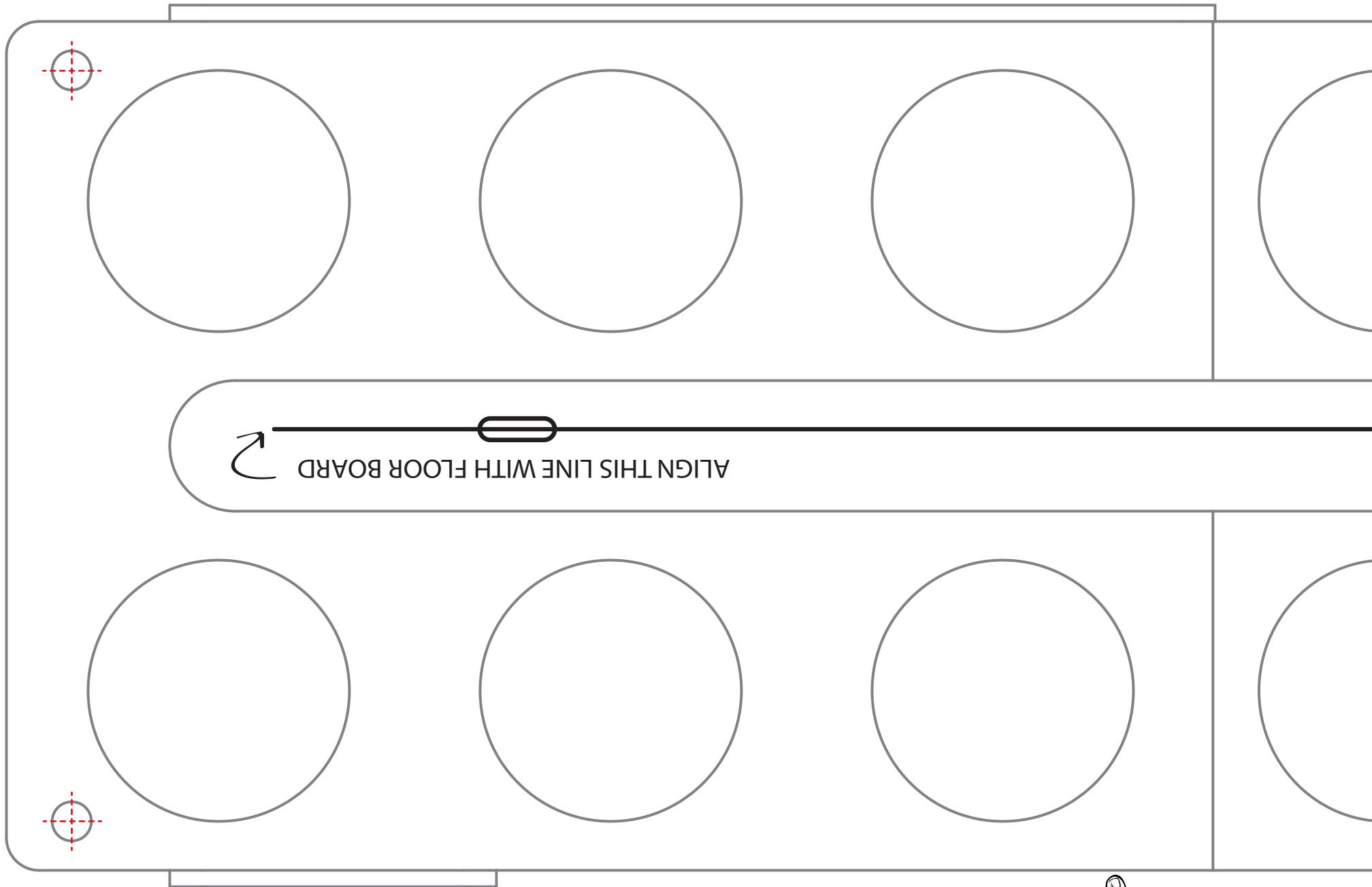

**IF YOU PRINTED THIS MANUAL
PLEASE READ THIS...**

Just as a cautionary step, please measure this box and make sure it is 1" x 1". Some copiers/printers may not print at 100% of actual size.



