

M998

CLIMATE CONTROL SYSTEM

CALIBRATION MANUAL

09.22

by RESTOMOD AIR 

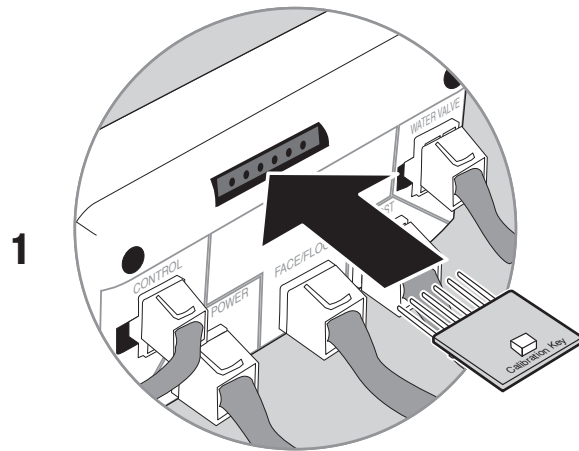

Insert Calibration Key as shown (LED side up)
into 6-pin connection in ECU

2

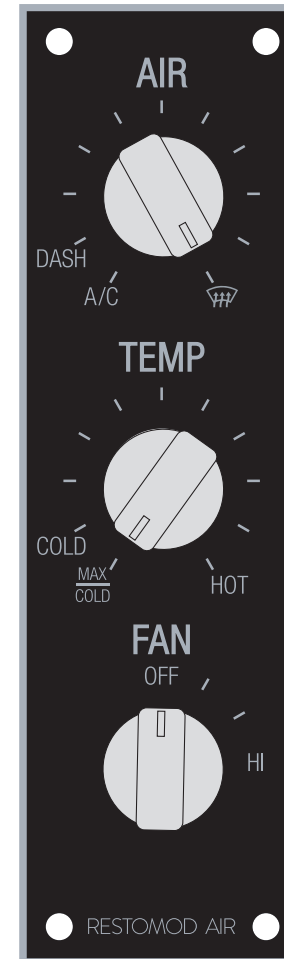

Start by positioning the knobs as shown:
Fan: OFF
Mode: DEFROST
Temp: MAX COLD

3

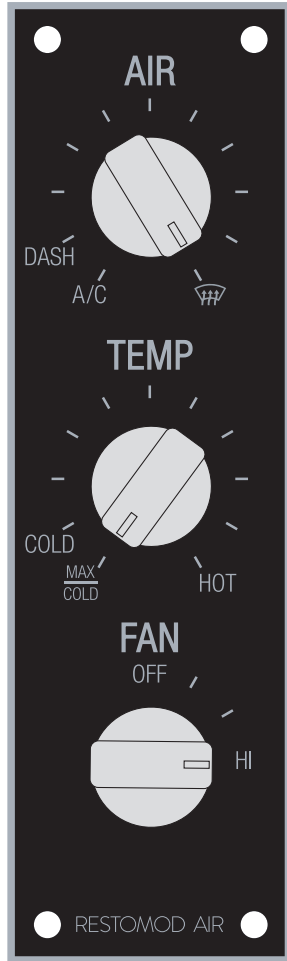

Move Fan Knob to High...

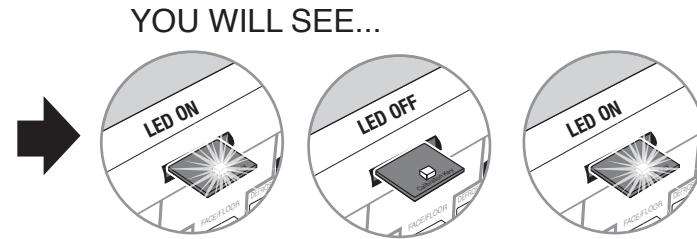

4

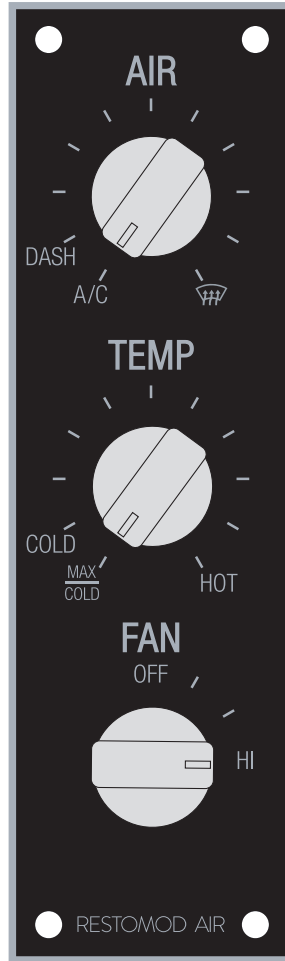

AFTER YOU MOVE THE KNOB YOU WILL SEE...

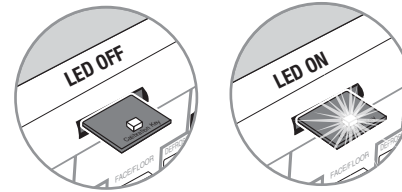

Move MODE knob to A/C
in one motion

5

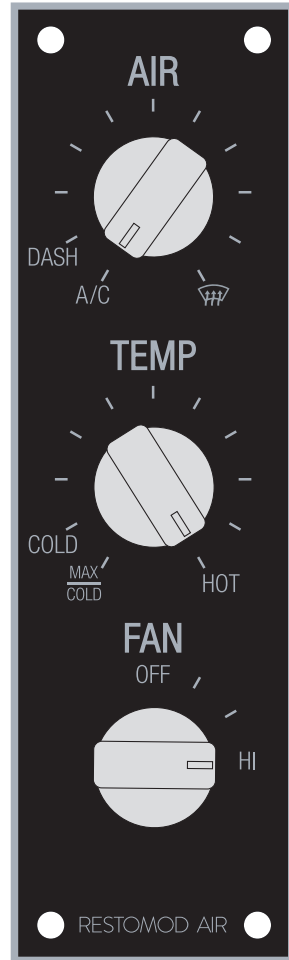

AFTER YOU MOVE THE KNOB YOU WILL SEE...

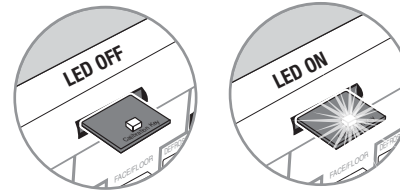

Move TEMP knob to HOT
in one motion

- 6 You will be able to hear the internal door(s) move back and forth and feel air coming out of the outlets

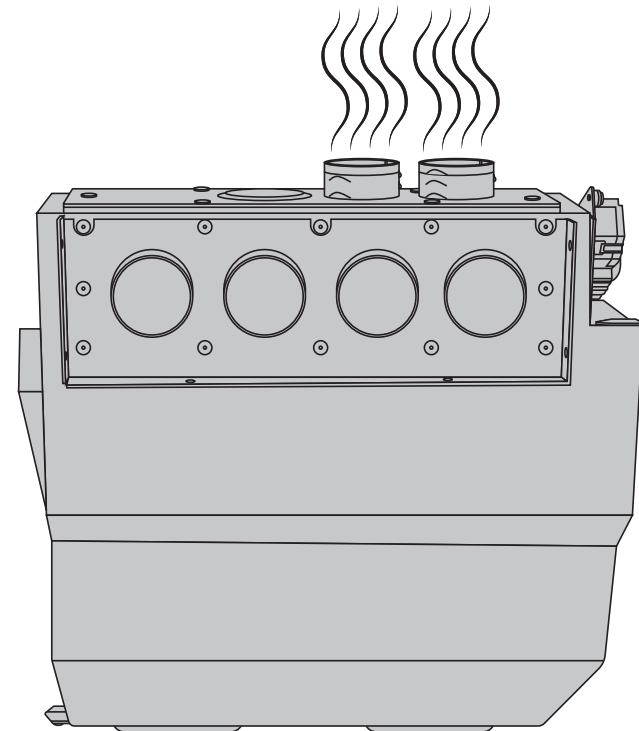
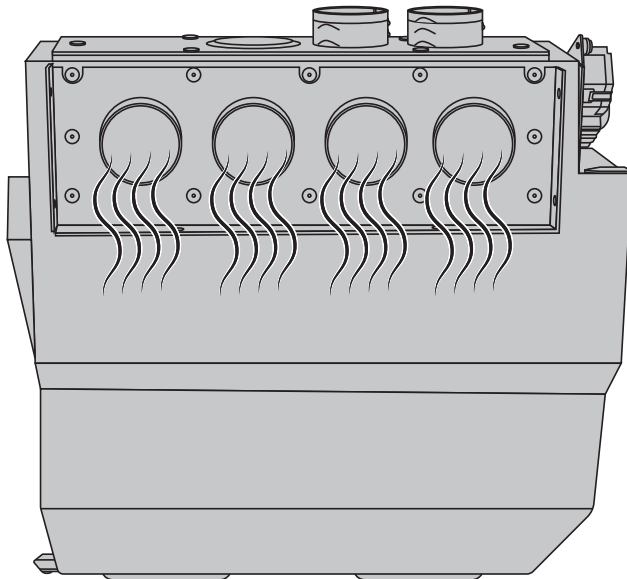
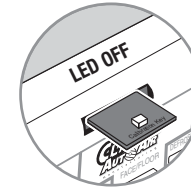

7

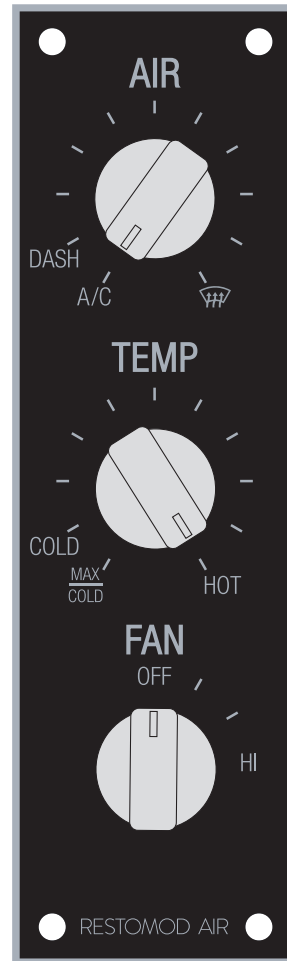

Move **FAN** knob to **OFF**

8

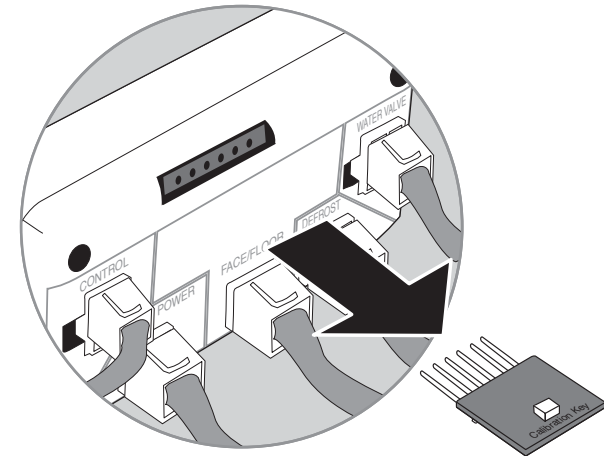

REMOVE CALIBRATION KEY FROM ECU
AND STORE IN A SAFE PLACE